**User's
Manual**

**Model SMST
(Style E)
Auto/Manual Station**

YEW SERIES 80

IM 1B4D3-02E

Notices

■ Regarding This User's Manual

- (1) This manual should be passed on the end user. Keep at least one extra copy of the manual in a safe place.
- (2) Read this manual carefully and fully understand how to operate this product before you start operation.
- (3) This manual is intended to describe the functions of this product. Yokogawa Electric Corporation (hereinafter simply referred to as Yokogawa) does not guarantee that the functions will suit a particular purpose of the user.
- (4) Under absolutely no circumstances may the contents of this manual in part or in whole be transcribed or copied without permission.
- (5) The contents of this manual are subject to change without prior notice.
- (6) Every effort has been made to ensure accuracy in the preparation of this manual. Should any error or omissions come to your attention however, please contact your nearest Yokogawa representative or our sales office.

■ Regarding Protection, Safety, and Prohibition against Unauthorized Modification

- (1) In order to protect the product and the system controlled by it against damage and ensure its safe use, make certain that all of the instructions and precautions relating to safety contained in this manual are strictly adhered to. Yokogawa does not guarantee safety if products are not handled according to these instructions.
- (2) Be sure to use the spare parts approved by Yokogawa when replacing parts or consumables.
- (3) Modification of the product is strictly prohibited.
- (4) Reverse engineering such as the disassembly or decompilation of software is strictly prohibited.
- (5) No portion of the software supplied by Yokogawa may be transferred, exchanged, leased or sublet for use by any third party without the prior permission of Yokogawa.

■ Force Majeure

- (1) Yokogawa does not make any warranties regarding the product except those mentioned in the WARRANTY that is provided separately.
- (2) Yokogawa assumes no liability to any party for any loss or damage, direct or indirect, caused by the user or any unpredictable defect of the product.

CONTENTS

<u>Section</u>	<u>Title</u>	<u>Page</u>
1.	INSPECTION	1-1
2.	GENERAL	2-1
2-1.	Standard Specifications	2-1
2-2.	Optional Specification	2-3
2-3.	Accessory	2-3
2-4.	Model and Suffix Codes	2-3
3.	INSTALLATION AND WIRING	3-1
3-1.	Wiring	3-1
3-2.	Terminal Board Wiring	3-2
4.	PRINCIPLES OF OPERATION	4-1
4-1.	Circuit Description	4-1
4-2.	Functions	4-4
5.	OPERATION	5-1
5-1.	Names and Functions of Components	5-1
5-2.	Preparations for Operation	5-7
5-3.	Normal Operation	5-9
5-4.	Actions when FAIL or ALM Lamps Lights	5-11
6.	MAINTENANCE	6-1
6-1.	Calibration Equipment	6-1
6-2.	Inspection and Adjustments	6-1
6-3.	Parts Replacement	6-3
●	Customer Maintenance Parts List	CMPL 1B4D3-03E
●	POWER SUPPLY TERMINALS for PANEL-MOUNTED INSTRUMENTS (for /HTB)	IM 1B4F1-11E

1. INSPECTION.

This instrument was thoroughly tested at the factory before shipment. However, when you receive this instrument:

- (1) Inspect for visible damage.
- (2) Confirm that the model and suffix codes shown on the shipping documents, and also on the nameplate on the side panel, are the same as on your order sheet.
- (3) Confirm that all accessories (see Section 2-4) are present.

If you have any questions about this instrument, please contact either your nearest Yokogawa Sales & Service Office or Yokogawa Electric Corporation, Tokyo, Japan.

2. GENERAL.

The SMST Auto/Manual Station is available in two types; SMST-111 provides remote settings for controllers and SMST-121 provides direct manipulated output to a control valve.

Both models are provided with front panel push-button switches for operation mode selection (cascade/manual), operation mode transfer by remote status input, and operation mode identification by status output as standard specifications.

Both SMST-111 and SMST-121 are discussed in this manual. Skip any explanations about specifications and descriptions that are not applicable to your instrument.

2-1. Standard Specifications.

Input/Output Signals

Analog Input: 1 to 5 V DC, 2 points.

Analog Output:

SMST-111: 1 to 5 V DC, 2 points.

SMST-121:

1 to 5 V DC, 2 points.

4 to 20 mA DC, 1 point.

Status Input: Contact or voltage level, 1 point.

Status Output: Transistor contact, 1 point.

Fail Output: Transistor contact, 1 point.

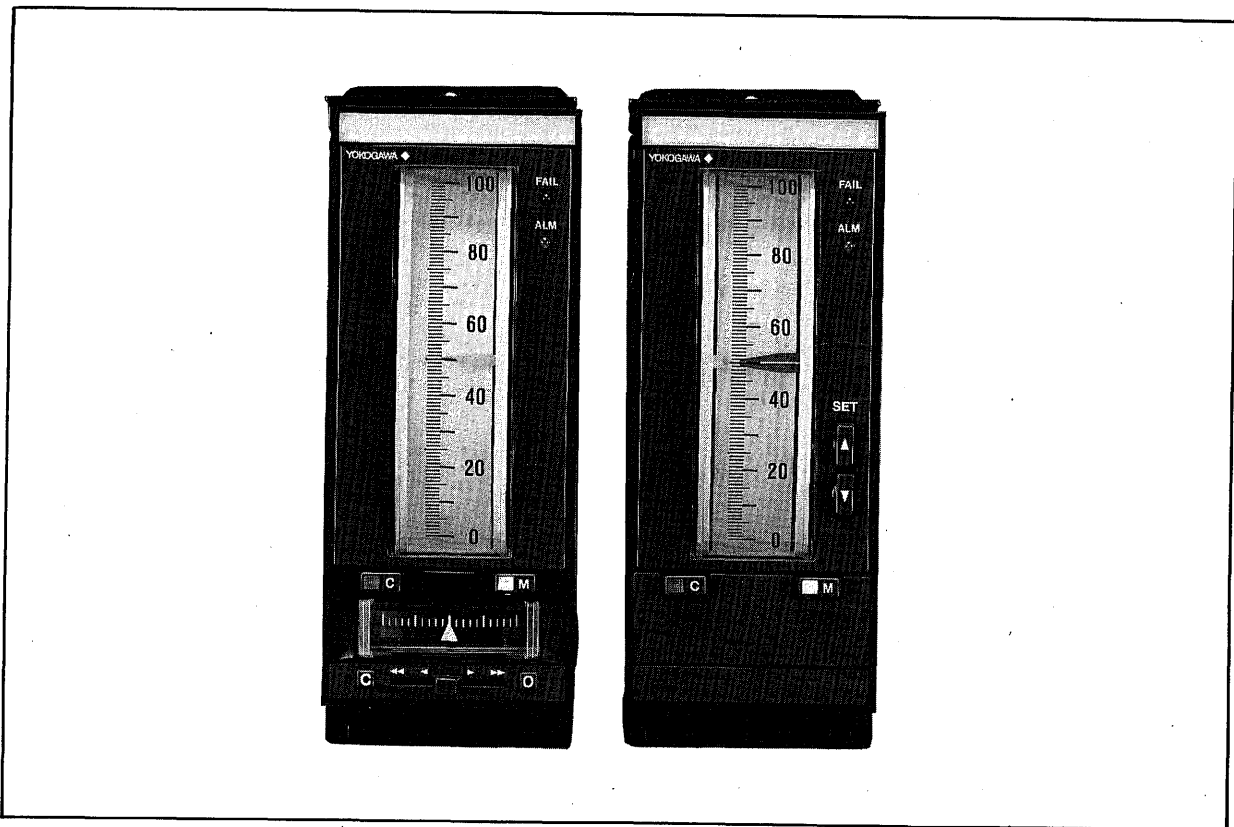

Figure 2-1. Front View.

Indicating, Setting and Operation Functions

Process Variable Indicator: 100 mm long scale, with red index.

Setpoint Indicator: SMST-111, 100 mm long scale, with blue index.

Output Indicator: SMST-121, 39 mm long scale, with memory indexes.

Setpoint: SMST-111.

Manual Setting: Setting speed; 40 sec./full scale.

External Setting: Cascade input signal; 1 to 5 mV DC.

Operation: SMST-121.

Manual Operation: Front-panel lever, two-speed operation.

Output Tracking: Output external manipulated input.

Mode Transfer: C/M pushbutton switches or contact input signals.

Operation mode identification:

Contact closed in C (cascade) mode.

Contact open in M (manual) mode.

Computation Functions

Square root and low-signal cutoff: Each user-selectable for process variable input. For signals below the "cutoff" point, a linear characteristic "output=input" applies.

SMST-111: Selected by side panel switch. Cutoff point is selected as either 1% or 0% of input span.

SMST-121: Selected by side panel mode setting. Cutoff point is adjustable between 0.0 and 100.0% of input range.

Cascade input gain bias computation (for SMST-121): User-selectable by side panel mode setting.

Computation formula:

$$CMV = CGN (CIN + CBI) + CBO$$

where CMV is computed output, CIN is cascade input, CGN (gain) is set in range -8.000 to 8.000, CBI (input bias) is set in range -106.3 to 106.3%, and CBO (output bias) is set in range -800.0 to 800.0%.

Output Limiter (for SMST-121): Can be set only in C (cascade) mode.

MH (High limit) adjustable from -6.3 to 106.3%.

ML (Low limit) adjustable from -6.3 to 106.3%.

Communication functions for supervisory systems:

Item	Functions and specifications	
Target card	LCS card in μ XL field control unit	
	LCS card in CENTUM filed control station	
Data transmitted	Process variable and operation mode	
	SMST-111	Set point
	SMST-121	Manipulated output Output limit setpoint
	Remote setting of parameters from a supervisory computer can be enabled/disabled.	
C (cascade) mode	In C (cascade) mode, either cascade input (analog) or supervisory computer set signals can be selected from the side panel.	
Cable length	Maximum length of SCCD cable to LCS card is 100m (328 ft).	

Mounting and Wiring

Mounting: Flush panel mounting. Instruments are in housings, and may be mounted individually or side-by-side. Instrument may be inclined with front up to 75° C from vertical (rear of instrument lower than front). (Indicator zero may need readjustment).

Wiring

Signal Wiring to/from Field: ISO M4 size (4 mm) screws on terminal board.

Power and Ground Wiring:

100 V version: JIS C 8303 two-pin plug with earthing contact. (IEC A5-15, UL498)

220 V version: CEE 7 VII (CENELEC standard) plug.

Cable Length: 300 mm.

Housing Dimensions: 182.5 (H) X 87 (W) X 480 (D) (mm) D: depth behind panel.

Weights:

Instrument Less Housing: 3 kg.

Housing: 2 kg (excluding mounting kit).

Normal Operating Conditions

Ambient Temperature: 0 to 50°C.

Ambient Humidity: 5 to 90% relative humidity (non-condensing).

Power Supply: Two versions, for "100 V" (standard) or "220 V" (option/A2ER). Both versions may use AC or DC, without change to the instrument:

Version	100 V	220 V
DC (polarity reversible)	20 to 130 V	120 to 340 V
AC (47 to 63 Hz)	80 to 138 V	138 to 264 V

2-2. Optional Specification.

- /A2ER: For "220 V version" power supply.
- /MTS: Controller supplied with kit for separate mounting.
- /SCF-G□M: Mounting kit bezel color change from standard color (black). Choose color from set of optional colors (see GS 22DIF1-E). Specify color code in space □.
- /NHS: No housing, instrument only. See GS 1B4F1-E to order housing separately.
- /NPE: Letters engraved on front panel nameplate.

2-3. Accessory.

Fuse (1 A): 1 each.
 Note: The fuse (S9510VK) is the dedicated fuse, Do not use it for other products.

2-4. Model and Suffix Codes.

Model	Suffix Code	Description
SMST	Auto/Manual Station
Indicator	-1	With process variable indicator
Functions	1	Pushbutton setpoint setting, 1 to 5 V output
	2	Manipulated output lever, 4 to 20 mA and 1 to 5 V output
C/M Transfer	1	With C/M transfer
Style Code	*E	Style E
Common Options	/A2ER . . .	220V power supply
	/MTS	With mounting kit
	/SCF-G□M	Bezel color change
	/NHS	Without housing
	/NPE	Nameplate engraving

3. INSTALLATION AND WIRING.

To install this instrument, refer to instruction manual IM 1B4F1-01E "Installation Manual for Panel-Mounted Instruments".

3-1. Wiring.

Connect external wires to the terminal board on the rear of the housing with 4 mm screws. Table 3-1 shows the wiring connections for this station. Connect wires in accordance with the model and suffix codes.

3-1-1. Wiring Precautions:

- (1) Furnish all cable ends with solderless crimp-on lugs.
- (2) Connect external voltage-and/or no-voltage-levels contact input so that the values specified in Figures 3-1 and 3-2 are obtained. Conductor resistance and consequent voltage drop must be taken into account. For contact input specifications, refer to GS 1B4D3-E at the end of this manual.
- (3) When driving remote equipment such as fail and alarm outputs, using transistor switch contacts, wire in accordance with the following instructions.
 - o Do not connect any load exceeding the contact rating of 30 V DC 200 mA.
 - o Connect a protection diode (surge absorber) in parallel with inductive loads such as relays to protect the transistor switch from transients when energizing or deenergizing external circuits. (See Figure 3-3).
 - o Match the power polarity to the terminal markings when connecting the power supply used to drive the external equipment. (See Figure 3-3).
 - o Transistor contacts cannot be used directly to switch (open and close) alternating current (AC) loads. Relays (or similar devices) must be used between the transistor switch and the load. (See Figure 3-4).

Input status		ON	OFF
		ON	OFF
Status input	Transistor contact	Contact closed (source up to 200 ohms)	Contact open (source at least 100 kohms)
	Voltage	LOW: -0.5 to +1 V	HIGH: 4.5 to 30V

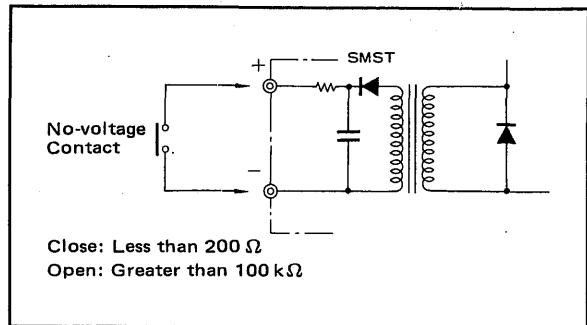

Figure 3-1. External Contact Input Connections.

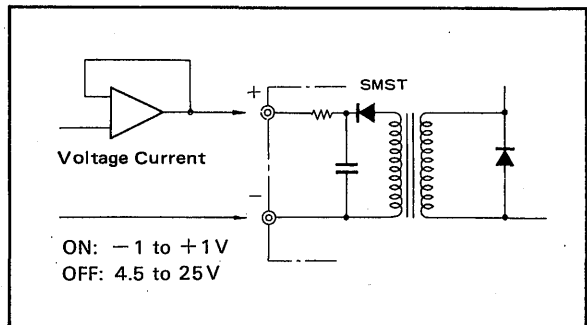

Figure 3-2. Voltage Level Input Connection.

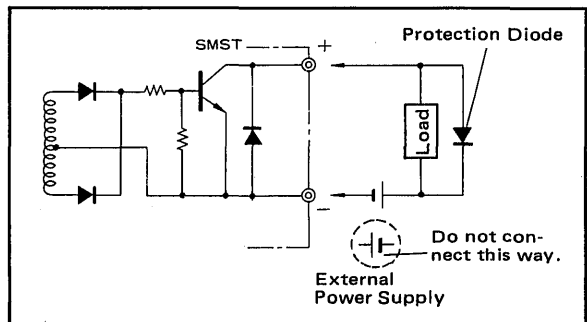

Figure 3-3. Contact Output Connection to External Load.

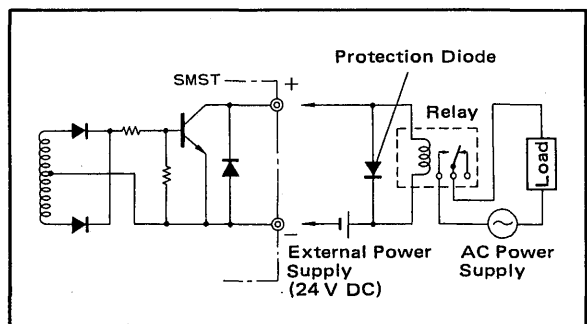

Figure 3-4. Connections for Switching an Alternating Current (AC) Load.

3-2. Terminal Board Wiring.

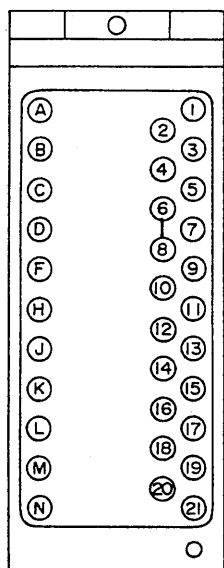

Figure 3-5. Terminal Arrangement.

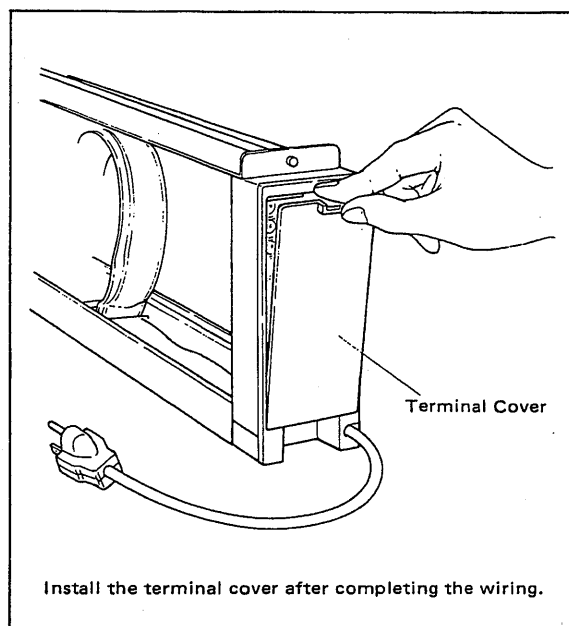

Figure 3-6. Removing the Terminal Cover.

Table 3-1. Terminal Connections.

Terminal Designation	Description	Terminal Designation	Description
1	+ > Process variable input, 1 to 5V DC	17	+ > Communication *1
2	- > Process variable input, 1 to 5V DC	18	- > Communication *1
3	+ > Auto ("cascade") input, 1 to 5V DC	19	
4	- > Auto ("cascade") input, 1 to 5V DC	20	
5		21	- Fail output (- terminal)
6		A	+ > Manipulated output 1, 4 to 20mA DC
7		B	- > Manipulated output 1, 4 to 20mA DC (SMST-121 only) *2
8		C	+ > Manipulated output 2 (SMST-121) or
9		D	- > Set point output 1 (SMST-111), 1 to 5V DC
10		F	+ > Manipulated output 3 (SMST-121) or
11	+ > Mode transfer (contact input)	H	- > Set point output 2 (SMST-111), 1 to 5V DC
12	- > Mode transfer (contact input)	J	
13		K	
14		L	
15	+ > Mode (contact output)	M	
16	- > Mode (contact output)	N	+ Fail output (+ terminal)

*1: Use shielded twisted-pair cable (SCCD, see GS 34B6T1-01E).

*2: If these terminal are not used, connect them together.

4. PRINCIPLES OF OPERATION.

4-1. Circuit Description.

Figure 4-1 and 4-2 show the circuit block diagrams of the Auto/Manual Station.

4-1-1. Analog Input Circuit.

The process variable input signal (1 to 5 V DC) is applied to the high resistance R_{IN} (1 M ohm) and filter circuit R1 and C1. If the input line is disconnected, resistor R_{IN} connects the input terminals (+ and -) together to prevent uncertain voltage signal from being applied to the input (+) line. Resistor R1 and capacitor C1 consist of an input filter circuit with time constant - approximately 0.1 seconds. The negative input terminal (-) is used as a "COMMON" terminal.

4-1-2. Analog/Digital Converter.

The analog input signal is selected by the input multiplexer and applied to the comparator A/D converter (consisting of a comparator, CPU, D/A converter, and buffer amplifier A1), where the analog input is converted to a digital signal and stored in the data memory (RAM).

4-1-3. Status Input Circuit.

The C/M transfer status input is insulated by the input transformer and is applied to the input port, then stored in the RAM. At the same time as the status input signal is read, the front panel switch (SET, C, A, M, and MV) statuses as well as the side panel switch (key and slide switches) statuses are read in the RAM.

4-1-4. Data Processing Circuit.

When the input data is read, the microprocessor (CPU) performs data processing according to control programs in the ROM. Controlled results are output via the D/A circuit or the output port. If a supervisory system is connected, controlled data is transmitted via the communication interface. The communication line is isolated by a photocoupler. The WDT (Watch Dog Timer) monitors the CPU - if the CPU fails, the FAIL lamp lights and a FAIL contact is closed. If the CPU fails, the circuit is separated from the manipulated output circuit (for SMST-121) automatically, and the manipulated output can be provided by adjusting the manual control lever.

4-1-5. Analog Output Circuit.

The analog output signal is fed to the current output circuit (for SMST-121) or voltage output circuit via the buffer amplifier and output multiplexer. The negative output line is used as the "common" line (see Figures 4-1 and 4-2).

4-1-6. Status Output Circuit.

The output signal is isolated from the output port by a transformer and output as an open collector contact.

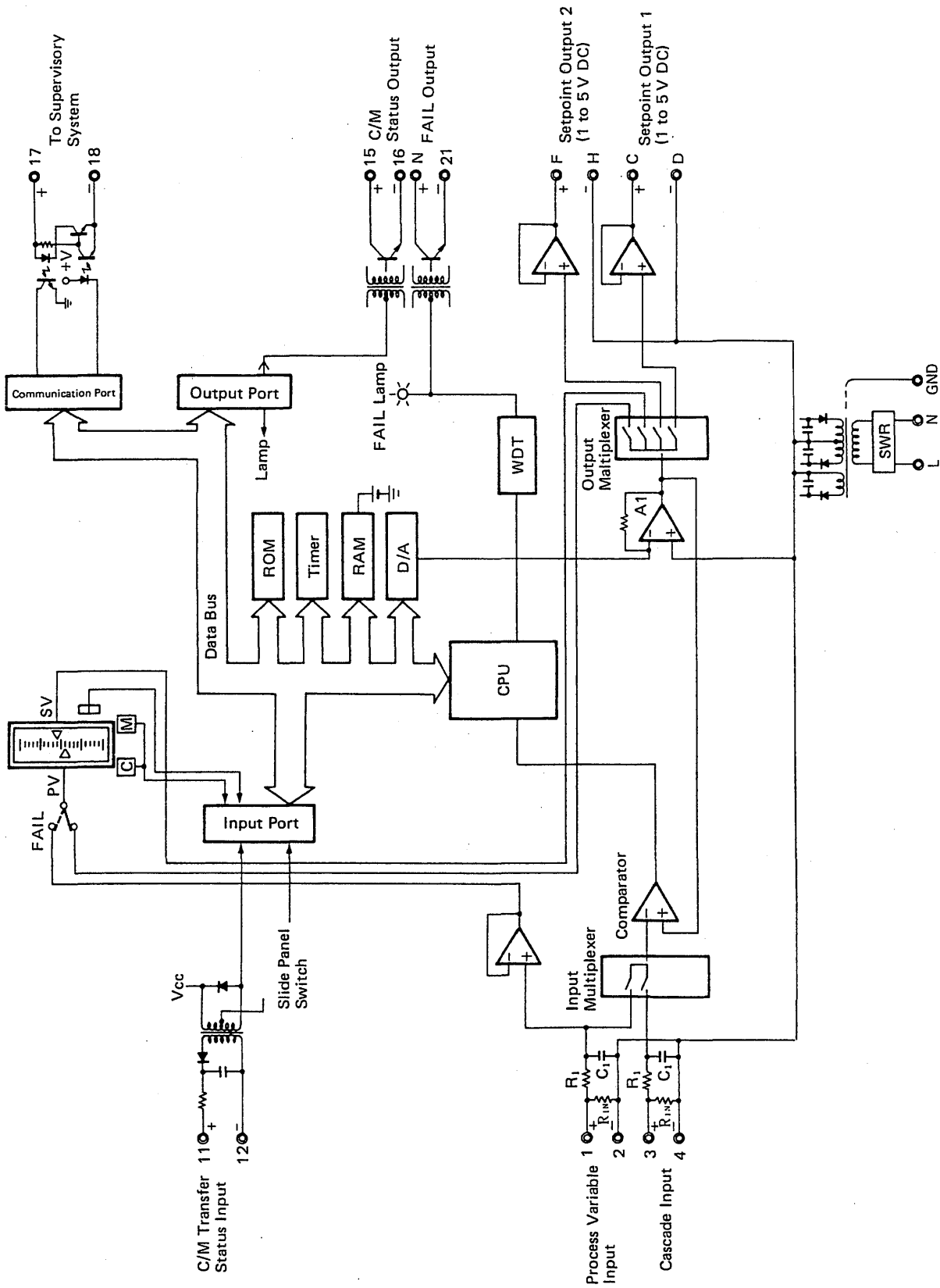

Figure 4-1. Schematic Diagram of Auto/Manual Station SMST-111.

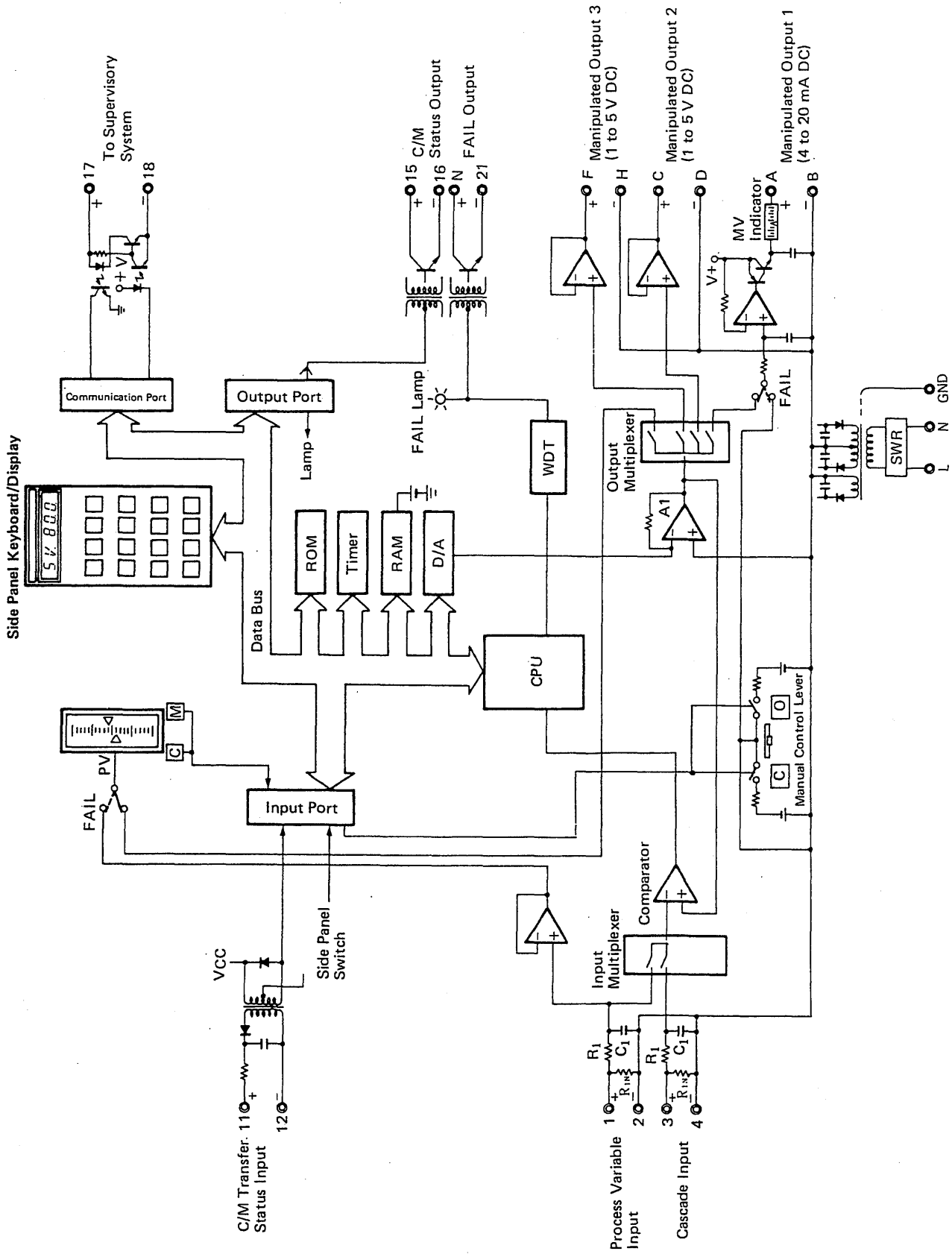

Figure 4-2. Schematic Diagram of Auto/Manual Station SMST-121.

4.2. Functions.

4-2-1. SMST-111.

Figure 4-3 shows the functional block diagram of the SMST-111.

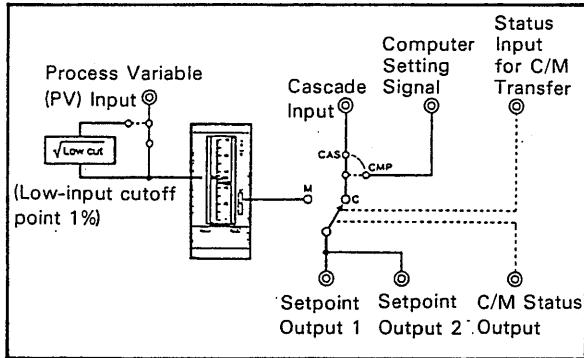

Figure 4-3. SMST-111 Functional Block Diagram.

Square Root Extraction

Process variable signals can be subjected to square root extraction. Low-signal cutoff for process variable input is user-selectable. Figure 4-4 shows the input-output characteristics when the low-signal cutoff is provided or not provided. For signals below the "cutoff" point, a linear characteristic "output = input" applies. When the input is greater than 1% of span, a square root extracted output is provided.

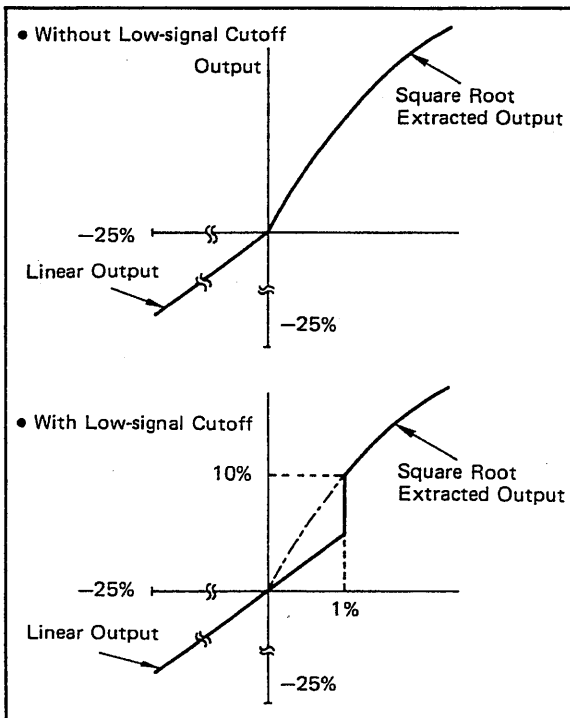

Figure 4-4. Square Root Extraction.

4-2-2. SMST-121.

Figure 4-5 shows the functional block diagram of the SMST-121.

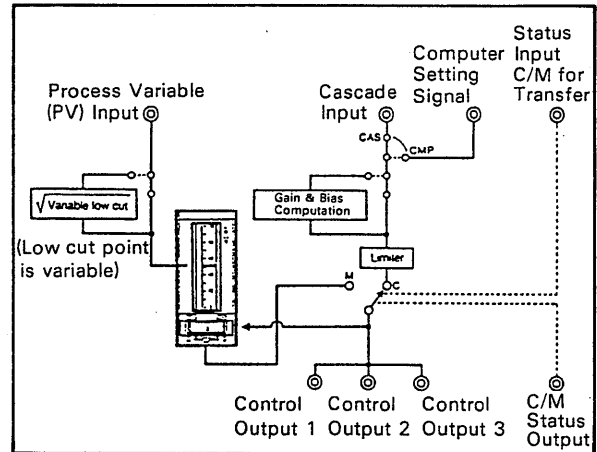

Figure 4-5. SMST-121 Functional Block Diagram.

Square Root Extraction

Process variable signals can be subjected to square root extraction (low-signal cutoff point is adjustable). Figure 4-6 shows the square root extracted output characteristics when the low-signal cutoff is provided. For signals below the "cutoff" point, a linear characteristic "output = input" applies. For signals above the "cutoff" point, square root extracted output is provided.

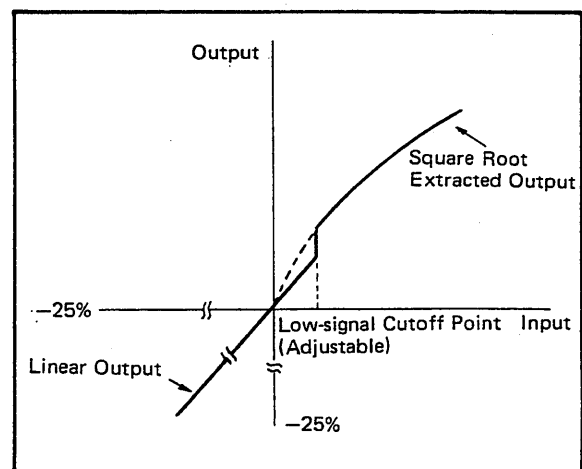

Figure 4-6. Square Root Extraction.

Cascade Input Scaling.

Cascade input can be subjected to gain and bias computation (user-selectable).

Computation formula:

$$CMV = CGN (CIN + CBI) + CBO$$

Here CMV is computed output, CIN is cascade input, CGN (gain) is set in range -8.000 to 8.000, CBI (input bias) is set in range -106.3 to 106.3%, CBO (output bias) is set in range -800.0 to 800.0%

Output Limiter (in C mode only).

MH (high limit) adjustable (-6.3 to 106.3%)

ML (low limit) adjustable (-6.3 to 106.3%)

Current Output Characteristics

With the output signal decreased, when the output signal is below -6% of span, the current output is approximately 0.8 mA (-20% of span). With the output signal increased, when the output signal is greater than -5% of span, the current output is released from 0.8 mA (-20% of span) and returned to 3.2 mA (-5% of span). When the output signal is above 100%, it increases up to 21 mA (106.25% of span).

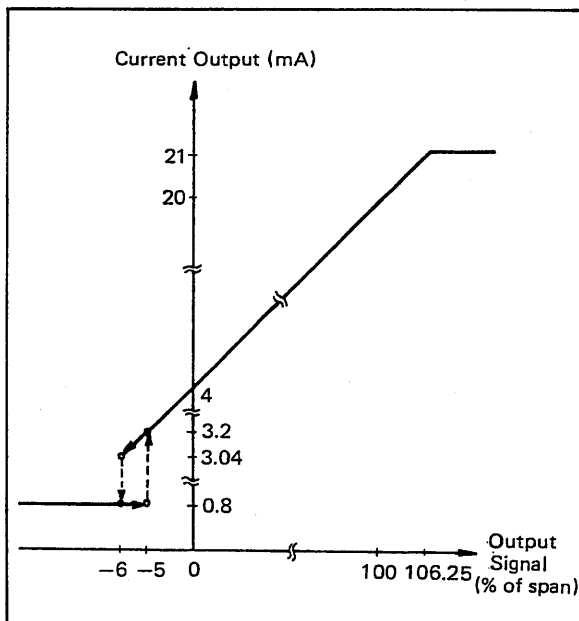

Figure 4-7. Current Output Characteristics.

Ramp Functions

For both SMST-111 and SMST-121 Auto/Manual stations, ramp functions are used for bumpless switching from [M] (local setpoint) to [C] (remote setpoint). The ramp rate is (full span/40 sec.).

For example, if the setpoint is switched from 50% in [M] mode to 75% in [C] mode, it takes 10 sec. for the output to ramp from 50% to 75% at this ramp rate, as shown in Figure 4-8.

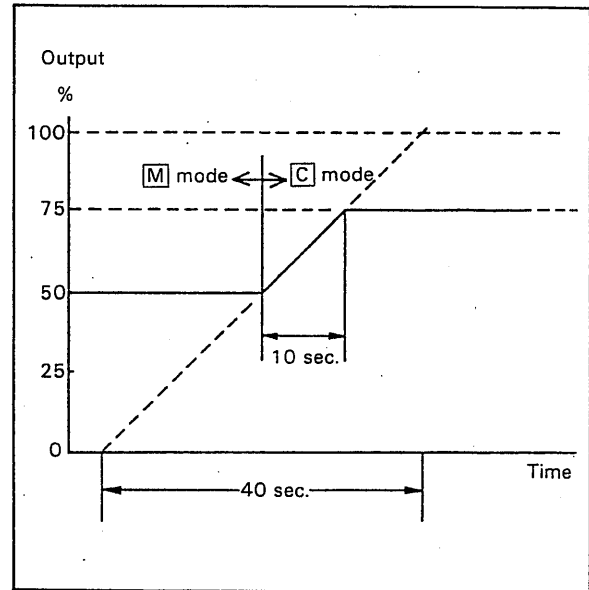

Figure 4-8. Ramp Functions.

5. OPERATION.

5-1. Names and Functions of Components.

5-1-1. Names and Functions.

Figure 5-1 through 5-3 show the names of components.

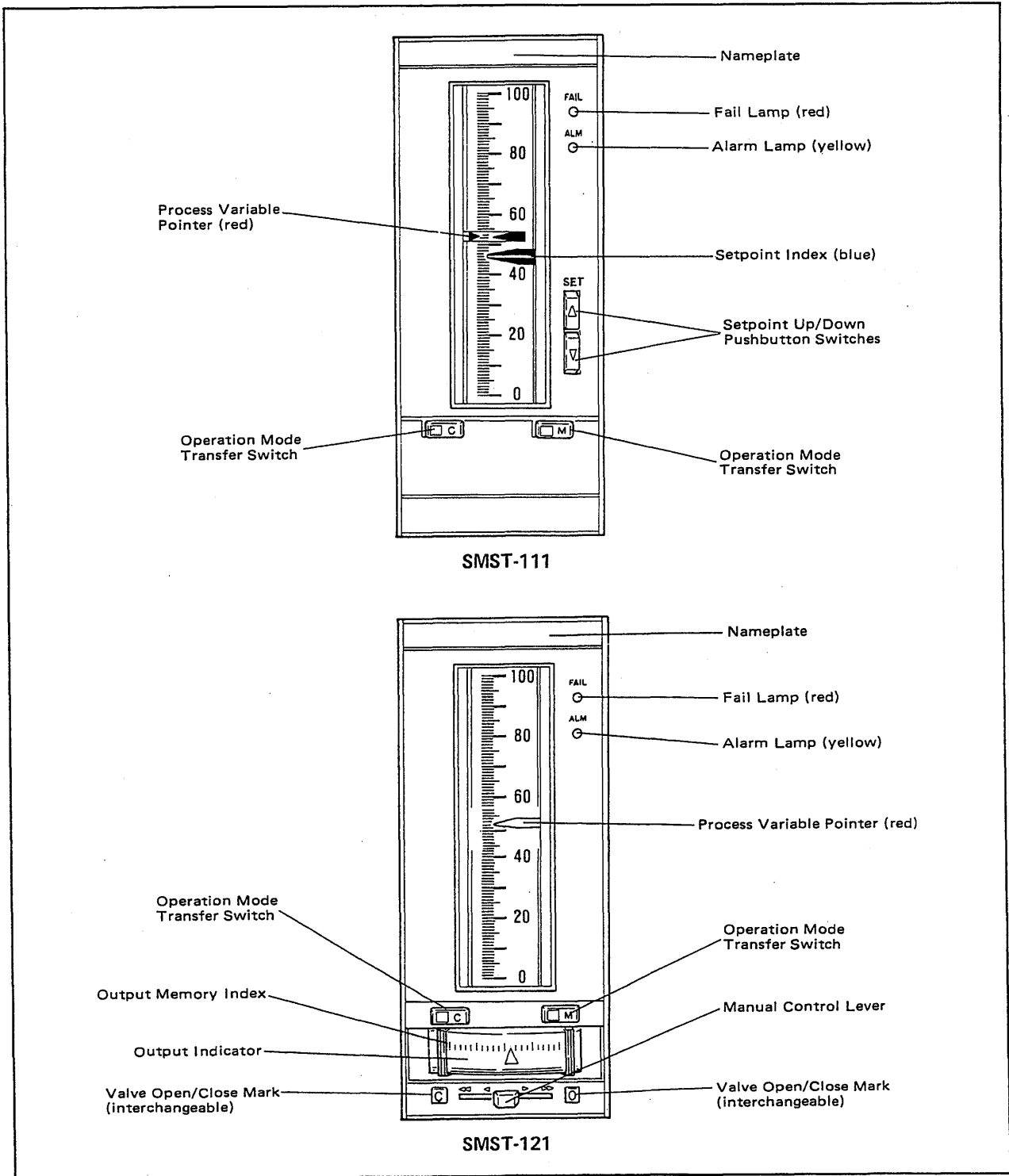

Figure 5-1. Front View.

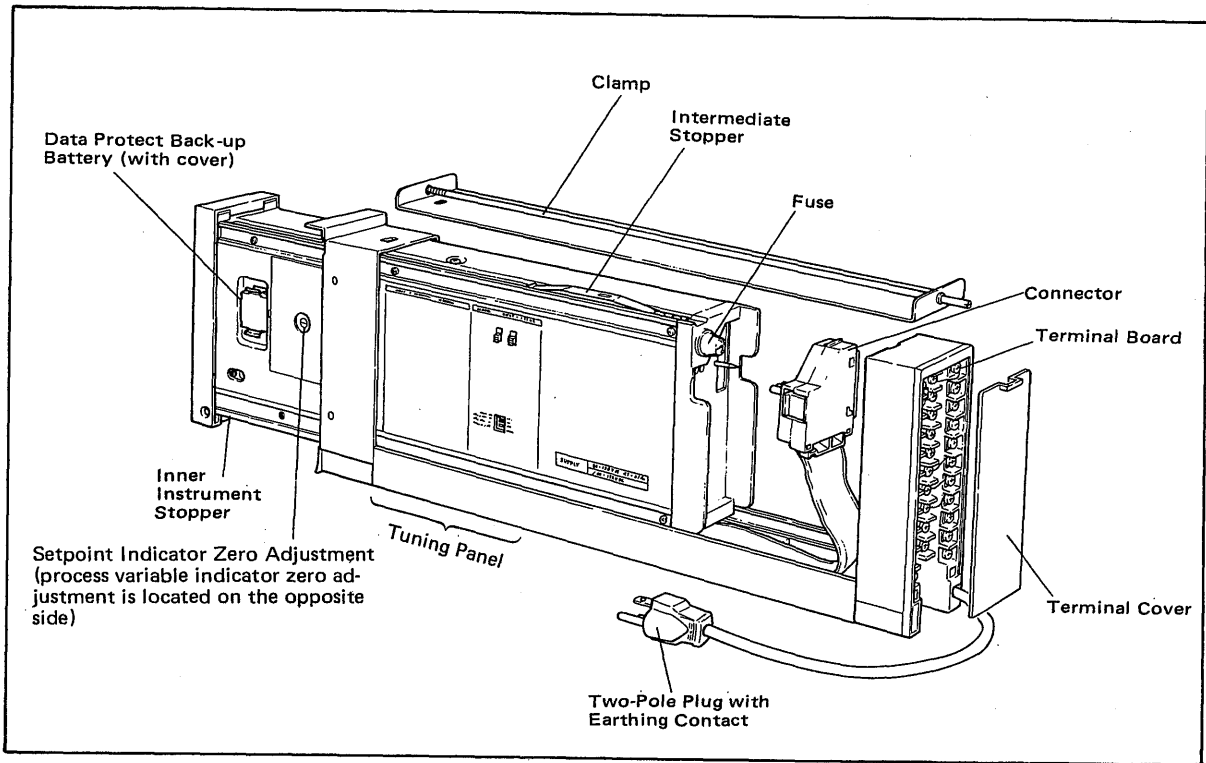

Figure 5-2. Right Side View of SMST-111.

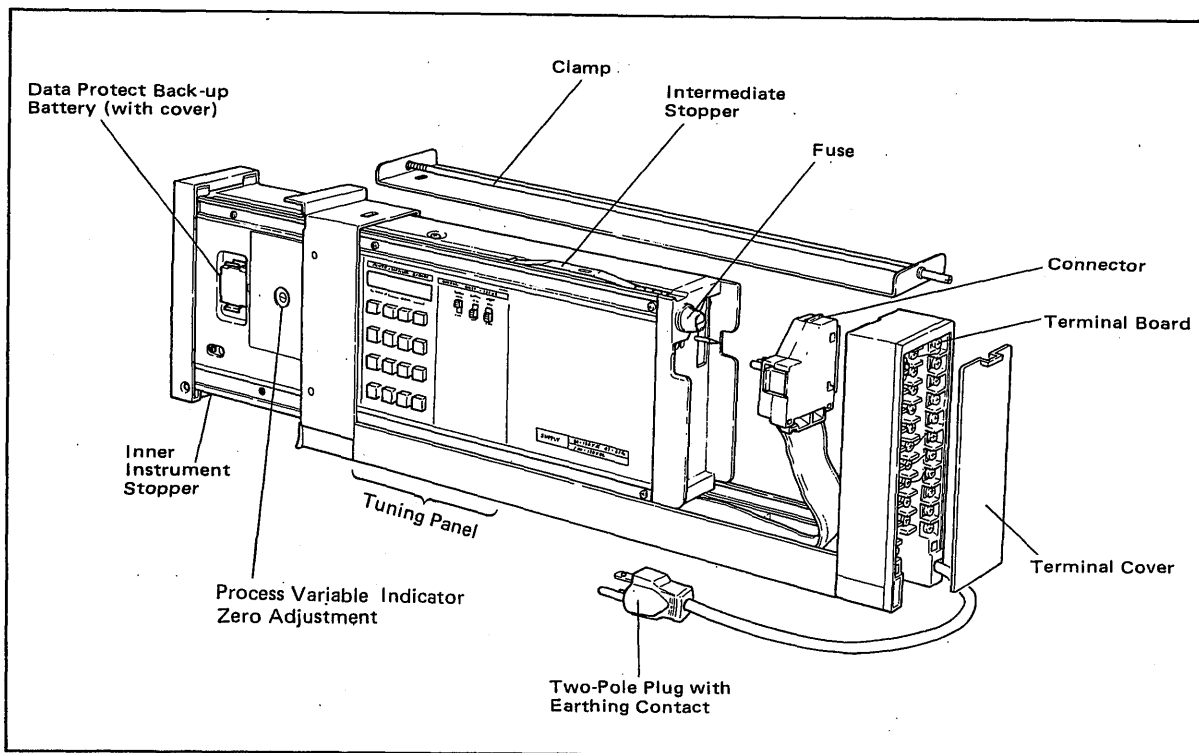

Figure 5-3. Right Side View of SMST-121.

(1) Fail Lamp (FAIL: red).

This lamp lights if any abnormality occurs in the computing or control circuits in this instrument. A fail contact (open) signal is output at the same time.

(2) Alarm Lamp (ALM: yellow).

This lamp lights when the input signal is above the operating range (including open-circuit and short-circuit conditions), or when the output circuit is open. It flashes when the data protect battery voltage is low.

(3) Process Variable Pointer (red).

This pointer indicates the process variable input value.

(4) Setpoint Index (blue) for SMST-111 Only.

This index shows the manual setpoint which is set with the setpoint up/down pushbutton on the front panel.

(5) Setpoint Up/Down Pushbutton for SMST-111 Only.

These switches are used to adjust the instrument setpoint in manual operation mode M.

▲ : Setpoint increases

▼ : Setpoint decreases

Setting Speed: 40 sec/full scale

Fine adjustment: When the pushbutton is pressed (approximately 0.2 sec), the setpoint moves in 0.1% step.

(6) Output Indicator for SMST-121 Only.

This indicator reading shows the current output signal (manipulated output) for this instrument.

(4 mA DC on the minimum scale and 20 mA DC on the maximum scale)

(7) Manual Output Lever SMST-121 Only.

The manipulated output signal is increased or decreased by the manual operation lever in mode M. In mode C, it is also possible to increase or decrease the manipulated output signal, when the operating status transfer (contact) input is open.

Operation: To increase the output, move the manual control lever to the right position. To decrease the output, move the lever to the left position.

Setting speed: SLOW ◀, ▶ 40 seconds/full scale.
FAST ◀◀, ▶▶ 4 seconds/full scale.

Fine adjustment: When the manual control lever is moved from neutral position to ◀ or ▶, the output decreases or increases in 0.1% step.

(8) Operation Mode Transfer Switch.

To change the operation mode, press the appropriate (C or M) press switch, on the front panel of the instrument. (Insure that the corresponding lamp illuminates.)

Mode **C**: A cascade input signal is employed as an output signal.

Mode **M**: In SMST-111, the setpoint signal is the value adjusted by the up/down press switches, and in SMST-121, the manipulated output signal is the value adjusted by the manual operation lever.

Transfer from Mode **C** to **M**: Balanceless and bumpless transfer.

Transfer from Mode **M** to **C**: Output ramps from manual setting to input value at a rate of 40 sec/full scale.

5-1-2. Tuning Panel Switches and Functions.

■ SMST-111

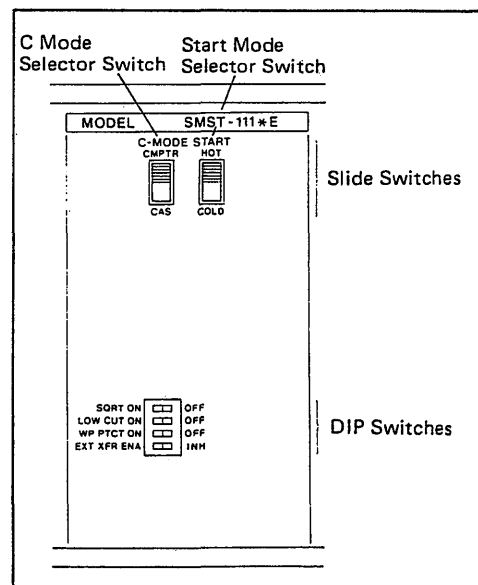

Figure 5-4. SMST-111 Tuning Panel.

(1) Slide and DIP Switches.

Table 5-1 shows the functions of SMST-111 slide and DIP switches on the tuning panel.

Table 5-1. SMST-111 Slide and DIP Switch Functions.

	Switches	Functions	Description
Slide Switches	C-MODE	Designates setting input value in C mode.	CMP : Setting signal from a supervisory computer CAS : Analog cascade signal
	START	Designates the restart status when power reverts to normal.	HOT : Restarts operation at the status immediately before the power failure. COLD : Restarts operation at the status -6.3% of 1 to 5 V output or 4 to 20 mA output in M mode. Note: For momentary failure less than 2 seconds, always carries out HOT start regardless of switch position.
DIP Switches	SQRT	Designates the square root extraction.	ON : Square root extraction OFF : Square root extraction is not carried out.
	LOW CUT	Designates low-signal cutoff for square root extraction.	ON : For signals less than 1% of input, a linear characteristic "Output = Input" applies. OFF : For signals below 0% output, a linear characteristic "Output = Input" applies.
	WR PTCT	Designates a supervisory system.	ON : Disables setting and control from a supervisory system (only monitoring is enabled.). OFF : Enables setting and control from a supervisory system.
	EXT XFR	Designates operation mode transfer status.	ENA : Valid. INH : Invalid.

■ SMST-121

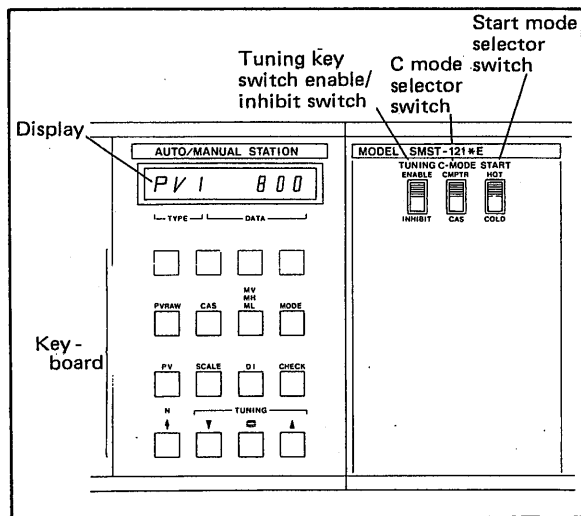
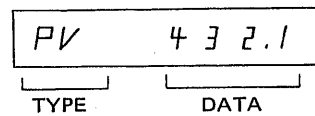

Figure 5-5. SMST-121 Tuning Panel.

(1) Display.

Displays the data type code (TYPE) and data value (DATA) for data selected from the keyboard (see below).



(2) Keyboard.

Used to call and change parameters and data. Tables 5-2 and 5-3 show the keyswitch names and functions.

Table 5-2. SMST-121 Side Panel Switches and Their Functions.

Name of Keyboard	Type (TYPE)	Number (N)	Name - Description	Display/ Set Range	Units	Settable	Initial Value
PVRAW	PIN	—	Process variable input	-25.0 to 135.0	%	x	—
	PSR	—	Square root extraction ON/OFF	0: OFF 1: ON	—	o	0
	PLC	—	Low-signal cutoff point	0.0 to 100.0	%	o	1.0
CAS	CIN	—	Cascade input value	-25.0 to 135.0	%	x	—
	CSW	—	Gain and bias computation	0: OFF 1: ON	—	o	0
	CGN	—	Gain	-8.000 to 8.000	—	o	1.000
	CBI	—	Input bias	-106.3 to 106.3	%	o	0.0
	CBO	—	Output bias	-800.0 to 800.0	%	o	0.0
	CMV	—	Computed CAS result	-6.3 to 106.3	%	x	—
MV	MV	—	Manipulated output signal	-20.0 to 106.3	%	(InMAN) o	—
MH	MH	—	Manipulated output signal, high limit value	-6.3 to 106.3	%	o	106.3
ML	ML	—	Manipulated output signal, low limit value	-6.3 to 106.3	%	o	-6.3
MODE	MODE	1 to 3	Operation mode	See Table 5-3.			—
PV	PV	—	Process variable input	Same as SCALE	—	x	—
SCALE	HI	—	Engineering units (corresponding to 100%)	-9999 to 9999	—	o	1000
	LO	—	Engineering units (corresponding to 0%)	-9999 to 9999	—	o	0
	DP	—	Decimal point position □ □ □ □ ↑ ↑ 1 4	1 to 4	—	o	3
DI	DI	—	Operation mode transfer status input	0/1	—	x	—
CHECK	CHECK	—	Self-diagnostic; Cause of fault is displayed by code.	See Table 5-4.			
N			Item number update (updates the type number N)	—	—	—	—
▼			To decrease data.	—	—	—	—
◀▶			Setting speed up (press together with ▲ or ▼)	—	—	—	—
▲			To increase data.	—	—	—	—

Table 5-3. SMST-121 Operation Mode.

MODE (N)	Setpoint	Operating Status	Initial Value
1 (Mode transfer status input)	0	Invalid	0
	1	Valid	
2 (Designates mode transfer status input)	0	Mode is transferred with status input open.	0
	1	Mode is transferred with status input closed.	
3 (Sets supervisory system)	0	Enables setting and control from a supervisory system.	0
	1	Disables setting and control from a supervisory system.	

(3) Slide Switches

Table 5-4 shows the functions of slide switches on the tuning panel.

Table 5-4. Functions of Slide Switches.

Switch Name	Functions	Description
TUNING	Key switches for tuning Designates Enable/Inhibit of (▼, ⊞, ▲) functions.	ENABLE : Enables to change setting. INHIBIT : Disables to change setting.
C-MODE	Designates the setting input value in C mode.	CMP : Setting signal from a supervisory system. CAS : Analog cascade signal.
START	Designates the restart status when recovers from power failure.	HOT : Restarts operation at the status immediately before the power failure. COLD : Restarts operation at the status -20% of 1 to 5V output or 4 to 20 mA output in the M mode. (Note: For momentary failure less than 2 seconds, always carries out HOT start regardless of the switch positions.)

■ Keyboard Operation (see Figure 5-6).

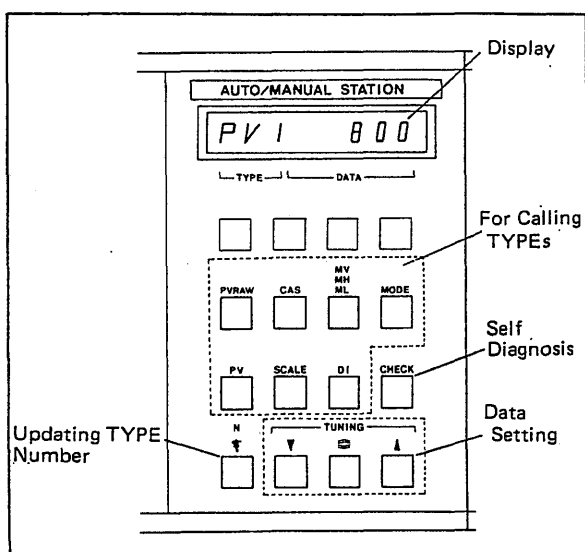

Figure 5-6. Keyboard Functions.

(1) Calling TYPE.

When a key for TYPE to be displayed is pressed, the TYPE same as designated to the key and its value (DATA) are displayed in the display.

More than one TYPE is allocated to the same keys. Those TYPEs are varied in turn for every pressing of the key.

[Example of Display and Key Operations]

1) MV · MH · ML key. An arrow corresponds to one key operation.

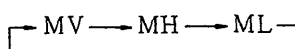

(2) Updating TYPE Number.

Pressing N (↑) key allows the TYPE number to be updated.

(3) Updating Data.

Pressing TUNING keys (▼, ⊞, or ▲) allows data to be increased or decreased.

This is effective only when the TUNING slide switch is set to ENABLE.

▲ : Data increase setting

⊞ : Setting for increase of data change rate (operate at the same time as ▲ or ▼ key.)

▼ : Data decrease setting

(4) Self Diagnosis.

Pressing CHECK key allows the operating condition of the controller to be checked. Calling procedure is the same as that in (1).

For details, see subsection 5-4-4.

(5) Turning the Display OFF.

About 30 minutes after the data setting is completed and all the key operations are finished, the display is automatically turned off.

This is done for saving power and the display is automatically turned on when the key operation is started again.

5-2. Preparations for Operation.

5-2-1. Preparation.

The preparation prior to operation can be performed with the Manual Station installed in the panel or placed on a service bench (the Manual Station must be installed in the housing).

5-2-2. Withdrawing the Instrument Body.

- (1) Push up the stopper spring at the bottom front of the internal unit and pull the instrument body out from the housing. (See Figure 5-7).

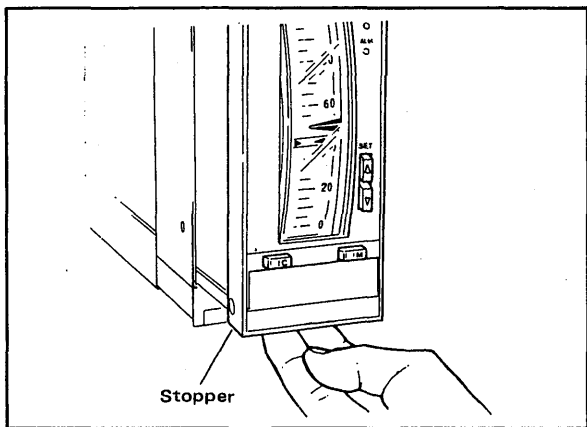

Figure 5-7. Withdrawing the Internal Unit.

- (2) The indicator body locks as it is pulled partially out from the housing. To pull the internal unit out further, press down the intermediate stopper located on the top of the internal unit, and pull the unit out from the housing (See Figure 5-8).

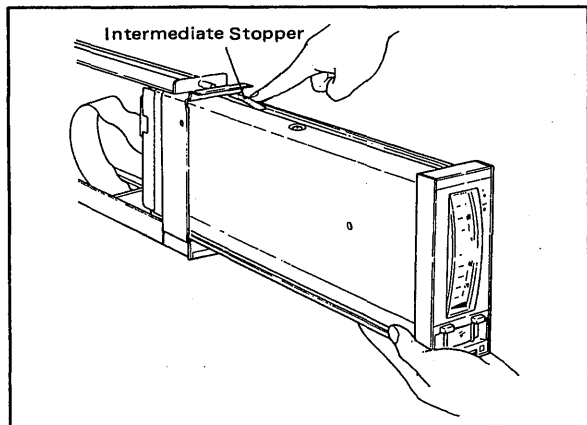

Figure 5-8. Withdrawing the Internal Unit.

- (3) Remove the connector from the internal unit. This separates the internal unit from the housing. (See Figure 5-9).

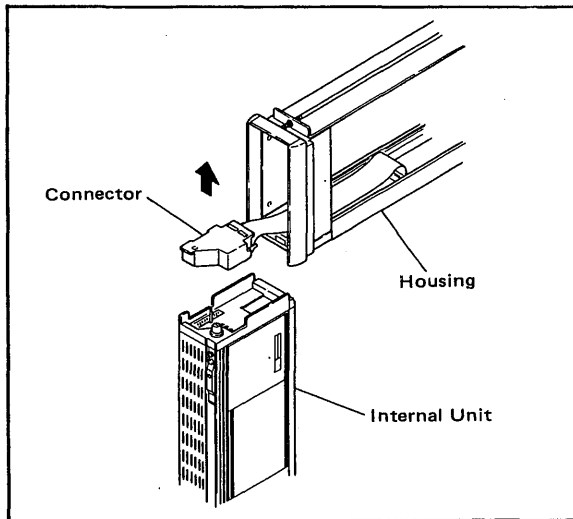

Figure 5-9. Disconnecting the Connector.

5-2-3. Parts Confirmation.

Confirm that the fuse and data protect battery are installed in the correct position. For installation instructions, refer to section 6-3 "Parts Replacement".

5-2-4. Preparations for Operation.

(1) Installing Valve Open/Close Marks – SMST-121 Only.

Set the valve open/close marks according to the required control valve acting direction (direct or reverse action). (See Figure 5-10.)

These marks can be pulled out by fingers or with tweezers and reinstalled by merely pressing them in position.

- C : CLOSE (valve close)
- O : OPEN (valve open)

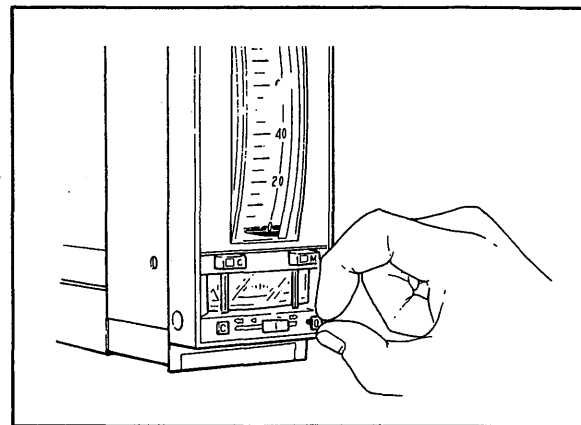

Figure 5-10. Setting the Valve Open/Close Mark.

(2) Setting Switches. (Figure 5-11)

Set the slide switches and DIP switches on the tuning panel to desired positions before power ON (see Tables 5-1 and 5-4).

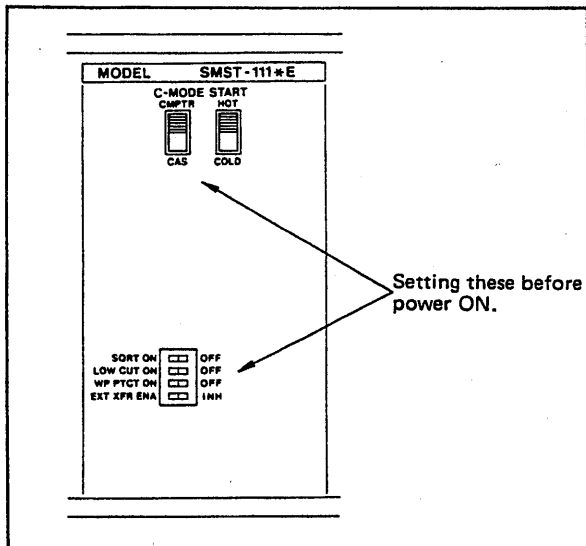

Figure 5-11. Setting Switches.

Then, turn power ON. When the TUNING switch is set to ENABLE, parameters can be set at the keyboard.

(3) Setting MODE < SMST-121 only >

Call MODE at the keyboard and set to the desired MODE with \blacktriangle or \blacktriangledown button (see Table 5-3).

[Example of Displaying and Setting]

Pushbutton Operation	Display	Remarks
MODE	MODE 1 0	
\blacktriangle	MODE 1 1	If 0 is alright, go to the next operation.
\uparrow	MODE 2 1	
\blacktriangledown	MODE 2 0	If 0 is alright, go to the next operation.
⋮	⋮	

\blacktriangle or \blacktriangledown operation takes about a second (for avoiding mis-setting.)

(4) Setting SCALE < SMST-121 only >

Prepare a scale representing a measured value in an engineering unit in the order of the maximum value, minimum value, and decimal point.

Maximum value (HI) : Set the displayed value when the internal data is 1.0 in a four digit integer with a sign.

Minimum value (LO) : Set the displayed value when the internal data is 0.0 in a four digit integer with a sign.

Decimal point (DP) : Set the position (digit) of the decimal point with a number which is assigned to the position of the decimal point.

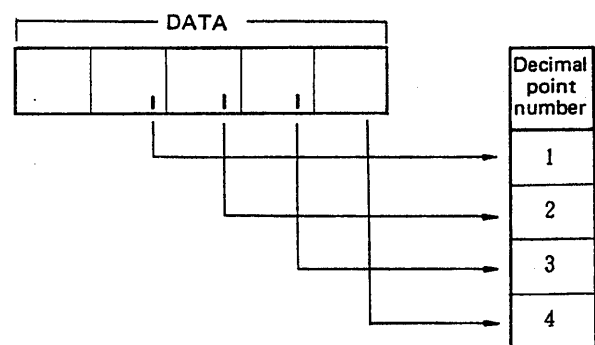

[Example] Preparing the scale for -10.00 to 40.00

Pushbutton Operation	Display	Remarks
SCALE	HI 1000 LTYPE LDATA	Current HI value is displayed in the DATA place.
\blacktriangle	HI 4000	\blacktriangle can be used together.
SCALE	LO 0 LTYPE LDATA	Current LO value is displayed in the DATA place.
\blacktriangledown	LO -1000	\blacktriangledown can be used together.
SCALE	DP 3	Current DP value is displayed in the DATA place.
\blacktriangledown	DP 2	For details of decimal point, see the figure above. However, use the \blacktriangle , \blacktriangledown keys to change a setting.

(5) Setting Other Parameters < SMST-121 only >

Set parameters required for computation without omission.

Table 5-2 lists those parameters and their setting ranges.

[Example of Setting Parameters]

Set the low-cut point to 10.0%.

Pushbutton Operation	Display	Remarks
PVRW	PIN -25.0	Current PIN value is displayed.
PVRW	PSR 0	Current PSR value is displayed.
▲	PSR 1	
PVRW	PLC 1.0	Current PLC value is displayed.
▲	PLC 10.0	can be used together.

Other parameters can also be set in the following order.

- ① Calling TYPE Call it with a key in seven TYPE keys.
- ② Calling number Update it with key.
- ③ Setting data Setting it with , or key.

(6) Initial Value.

Initial values are factory default values. (see Tables 5-2 and 5-3.)

When the data set at the keyboard are lost due to power or battery failures, the initial values are read as set data to start control.

(7) Tilted Mounting.

If the instrument is mounted in a tilted condition, it is necessary to adjust the zero point of the indicator. Properly adjust it according to the chapter describing "Inspection" and "adjustment".

When all of the preparative operations are completed, pull the power cord plug off the outlet, mount the instrument onto the panel, and then make signal cable wiring and turn power ON.

5-3. Normal Operation.

This section explains manual settings (SMST-111), manual output operating procedures (SMST-121) and operation mode transfers.

5-3-1. Manual Mode Setting with Setpoint Up/Down (SET) Press Switch (SMST-111).

- (1) Press mode press switch on the front panel to set the instrument in manual operation mode. Insure that lamp lights. (See Figure 5-12).

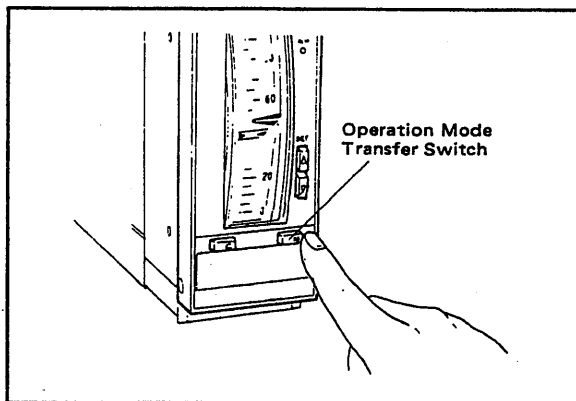

Figure 5-12. Operation Mode Transfer.

- (2) Using the setpoint up/down (SET) pushbutton switches, set the desired setpoint. (See Figure 5-13).

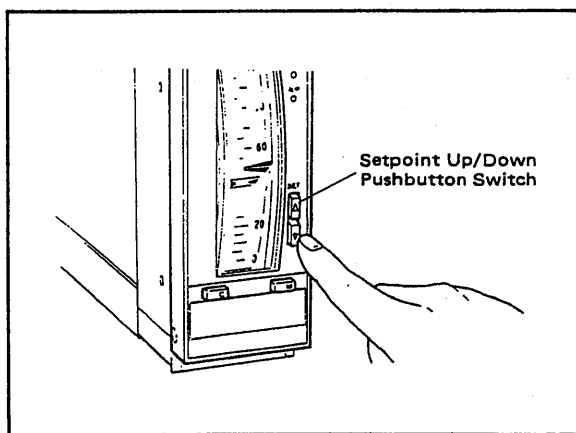

Figure 5-13. Adjusting the Setpoint.

- (3) When the cascade input signal is connected, press the mode switch on the front panel to transfer the cascade output signal to manual control output signal.

5-3-2. Control Output Operation with Manual Operation Lever (SMST-121).

- (1) Set the manual operation lever to **M** for operation mode. (Refer to 5-3-1.)
- (2) Move the manual operation lever to the left (or the right) to adjust the output signal. (See Figure 5-14.)

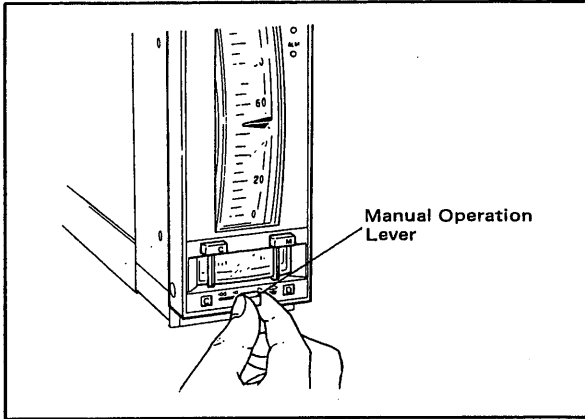

Figure 5-14. Manual Operation.

- (3) When the cascade input signal is connected, press the C mode switch on the front panel to transfer the cascade output signal to manual control output signal.

- (4) Setting parameters on the tuning panel. When parameters are to be changed, pull out the internal unit and set new parameters on the tuning panel. After setting the parameters, turn the ENABLE/INHIBIT switch to INHIBIT position.

When replacing the SMST-121, insert the connector of the cable from the SPBD standby manual station into the jack at the bottom of the housing to route the current output signal from the SMST to the SPBD. (See Figure 5-15).

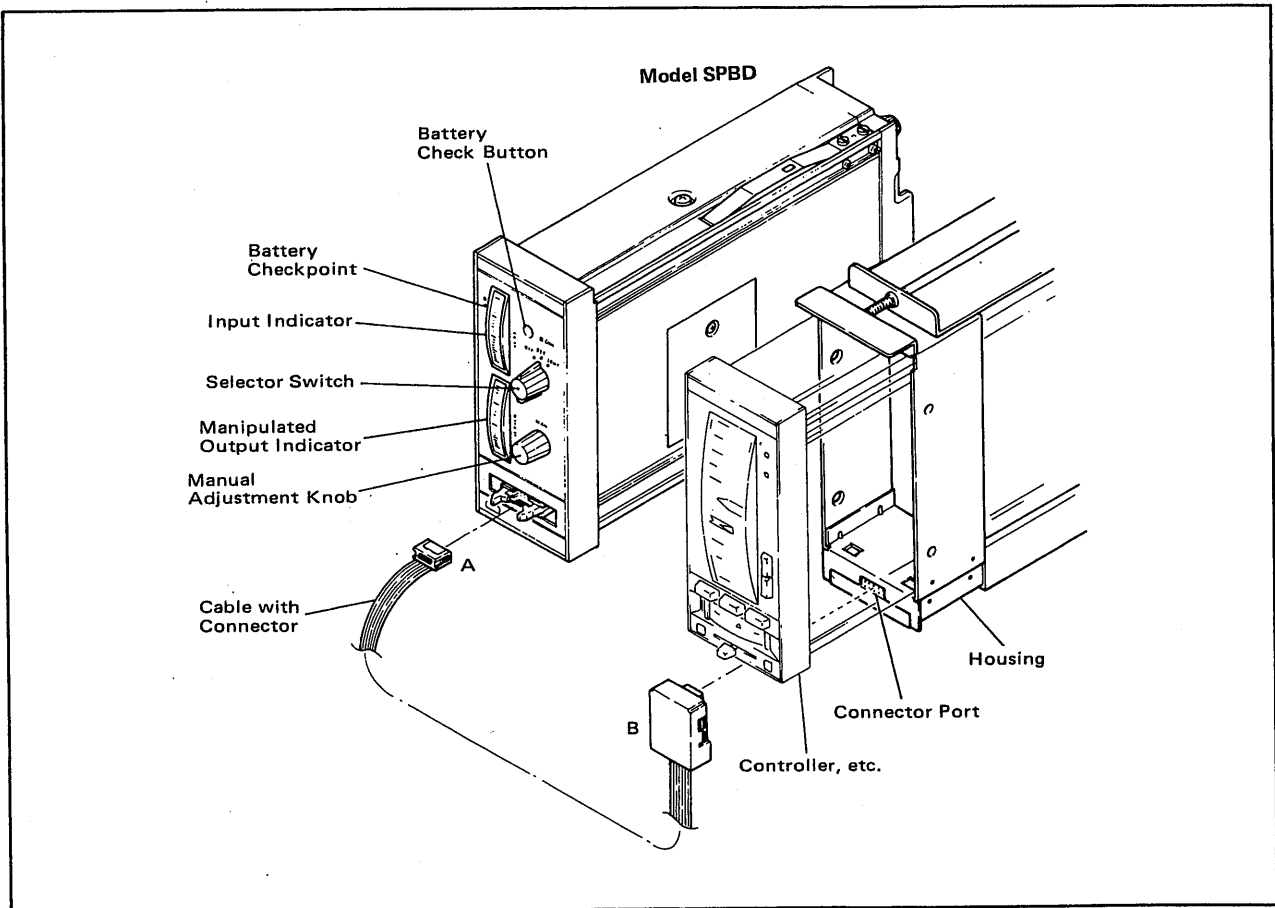

Figure 5-15. SPBD Connection.

5-4. Actions When the FAIL or ALM Lamps Light.

Model SMST auto/manual station is furnished with a FAIL lamp and an ALM lamp to visually indicate failures in the controller itself and signal errors, respectively. Whenever a lamp lights or begins to flash, take appropriate corrective action promptly.

5-4-1. Actions When FAIL Lamp Illuminates.

The FAIL lamp, when lit, indicates that a serious failure has occurred in the controller.

- (1) Monitor the current output signal and set it, with the manual operation lever, to a value that does not adversely affect the process.

The PV indicator gives correct readings at this time.

(If the FAIL lamp lights, the controller holds analog and status outputs just before a failure occurs. The manual operation lever directly controls the current output during failure. But, this cannot hold the controller output for a long term. If the output has to be held, use the SPBD manual control station as described in the next step (2). Voltage output signals will gradually decrease with time. For either output, incorrect value may be held depending which part of the circuit failed.)

- (2) Insert the cable from the SPBD manual control station into the jack at the bottom of the housing and switch the output signal from the SMST to the SPBD. (See Figure 5-15.)
- (3) Select the CHECK switch on the tuning panel for possible causes of a failure. (See 5-4-4.)

5-4-2. Actions When ALM Lamp Illuminates.

The ALM lamp, when lit, indicates that the wire is disconnected.

Select the CHECK and ALARM switches on the tuning panel for possible causes of a failure.

Take appropriate corrective action depending on the cause of the problem.

5-4-3. Actions When ALM Lamp Flashes.

The ALM lamp begins to flash when the data protect battery voltage drops. Replace the battery as instructed in Section 6-3-4.

Notes:

- (1) When the ALM lamp begins to flash during normal operation, replace the battery immediately.
- (2) A flashing ALM lamp overrides a continuous illuminated alarm lamp. No alarm status can be indicated, therefore, while the ALM lamp is flashing. (Other alarms can still be displayed on the tuning panel.)

**5-4-4. Description of CHECK Display.
(for SMST-121)**

Items displayed when the CHECK/ALARM/MODE switch is in CHECK position are as follows:

Lamp	CHECK Code	Self-diagnostic Functions
—	0 0	Normal.
FAIL	0 1	A/D converter abnormal.
FAIL	0 2	D/A converter abnormal.
ALM	0 4	Computing range overflow.
ALM	0 8	Process variable input overrange, communication abnormal.
ALM	2 0	Memory backup battery not installed or voltage too low (lamp flashes).
ALM	4 0	Current output line open or overload.
ALM	8 0	Internal data lost (see Note below).
ALM	PWR ERR	Supply voltage too low.
FAIL	—	Instrument fails.

Note: If ALM lamp lights and CHECK code 80 is displayed, parameters have been already initialized. Check PID parameters and reset them.

If two or more faults occur simultaneously, the hexadecimal sum of their code numbers is displayed.

< Example >

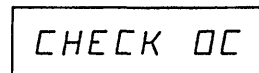

0C = 04 + 08 (computation range overflow, process variable input out of range)

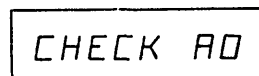

A0 = 20 + 80 (memory backup battery voltage too low, internal data lost)

When the cause of the fault is removed, the lamp turns OFF and the display reverts to 00 (normal). But code 80 does not revert to 00; press the  key to set 00.

6. MAINTENANCE.

This chapter explains the adjustment procedure for the process variable indicator and setpoint indicator, as well as the parts replacement procedure.

6-1. Calibration Equipment.

- (1) DC voltage/current standard.
YOKOGAWA's Model 7651 or equivalent .1unit
- (2) Universal digital voltmeter.
YOKOGAWA's Model 7562 or equivalent .1unit

6-2. Inspection and Adjustments.

6-2-1. Process Variable Pointer Inspection and Adjustments.

- (1) Apply 3.0 V DC to process variable (PV) terminal (terminal No. 1 (+) and terminal No. 2 (-)) from a DC voltage/current standard.
- (2) Check that the PV pointer reads the calibration marks on the scale within $\pm 0.5\%$ of 50%.
- (3) If the specified accuracy is not obtained, adjust the PV pointer zero adjustment until the pointer reads 50% on the scale.
- (4) Change input signal to 1.0 V, 2.0 V, 4.0 V and 5.0 V DC, and check that the PV pointer matches 0%, 25%, 75% and 100% calibration marks respectively. Tolerance is $\pm 0.5\%$ of span.
- (5) In (4), if pointer doesn't read within tolerance of calibration mark, input 3.0 V DC again and adjust until pointer reads within $50\% \pm 0.5\%$.
- (6) Check the indicator accuracy at each point and repeat steps (4) and (5) until the required accuracy is obtained at each point.

6-2-2. Setpoint Index Inspection and Adjustments (SMST-111 only).

- (1) Connect the DC voltage/current standard to cascade input terminals (terminal No. 3 (+) and terminal No. 4 (-)) and apply 3.0 V DC.
- (2) Select operation mode **C**.
- (3) After this, adjust in the same way as Process Variable Pointer. Setpoint Index Zero Adjustment is shown in Figure 6-3.

6-2-3. Manipulated Output Pointer Zero Adjustment (SMST-121 only).

- (1) Connect DC Voltage/Current Standard (Model 7562) to current output terminal (terminal number A (+), B (-)). Select operation mode **M**.
- (2) Set the output pointer at main scale at the center of the scale. Confirm that output is 12 mA (Tolerance is $\pm 2.5\%$).

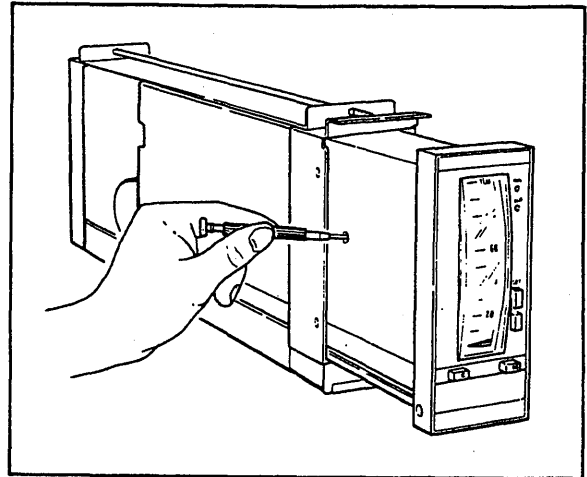

Figure 6-1. SMST-111 Measurement Pointer Zero Adjustment.

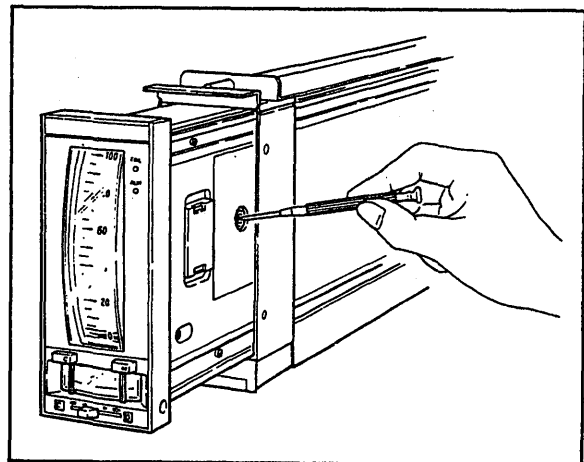

Figure 6-2. SMST-121 Measurement Pointer Zero Adjustment.

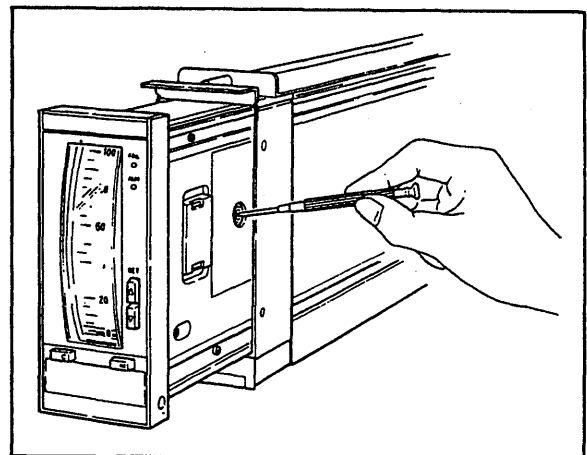

Figure 6-3. SMST-111 Setpoint Index Zero Adjustment.

- (3) When the reading is outside of tolerance, adjust the zero adjustment screw so the output pointer points to the major scale graduation in the center of the scale. (Figure 6-4, 5).
- (4) Next, set the output pointer at the leftmost major scale graduation, at the second major scale graduation from the left, at the second major scale graduation from the right, and at the rightmost major scale graduation. Verify that the ammeter reads 4 mA, 8 mA, 16 mA, and 20 mA respectively. (The tolerance is $\pm 2.5\%$.)
- (5) If the tolerance is exceeded in (4), return to (2) and make fine adjustments with the readings until all readings fall within the tolerance.
- (6) Repeat (4) and (5) until the readings at all points are within tolerance.

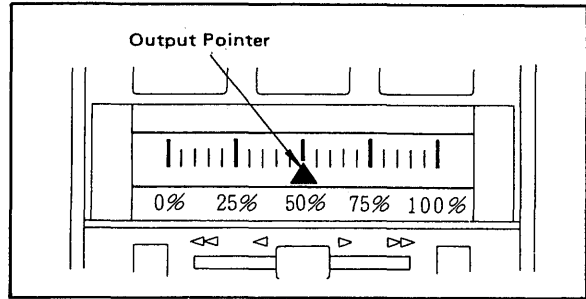

Figure 6-4. Output Indicator Major Scale Graduation.

6-2-4. Inclined Mounting.

For an inclined controller, set it up at the actual mounting angle and adjust its measurement pointer and set point as instructed in Sections 6-2-1 and 6-2-2, respectively.

6-2-5. Operation Mode Transfer with External Contact.

Confirm operation mode transfer referring to Table 6-1, 6-2.

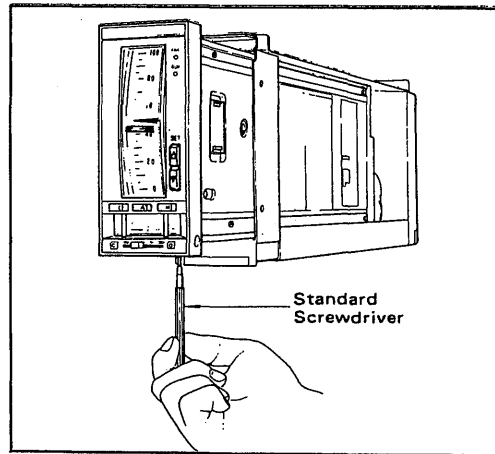

Figure 6-5. Zero Adjustment of Output Indicator.

Table 6-1. SMST-111 Operation Mode Transfer with External Contact.

Operation Mode Display Lamp	DIP Switch EXT XFR	External Contact Input	Operation Mode	Operation Mode Display Lamp	Operation Mode Status Output
Lamp M lights	ENA INH	OPEN CLOSED	M	Lamp M lights	OPEN
Lamp C lights	ENA	OPEN	M	Lamp C flashes	OPEN
		CLOSED	C	Lamp C lights	CLOSED
Lamp C lights	INH	OPEN	C	Lamp C lights	CLOSED
		CLOSED			

Table 6-2. SMST-121 Operation Mode Transfer with External Contact.

Operation Mode Display Lamp	MODE 1	MODE 2	External Contact Input	Operation Mode	Operation Mode Display Lamp	Operation Mode Status Output	
Lamp M lights	0	0	OPEN	M	Lamp M lights	OPEN	
	1	1	CLOSED				
Lamp C lights	0	0	OPEN	C	Lamp C lights	CLOSED	
			CLOSED				
	1	0	OPEN	M	Lamp C flashes	OPEN	
			CLOSED	C	Lamp C lights	CLOSED	
		1	1	OPEN	C	Lamp C lights	CLOSED
				CLOSED	M	Lamp C flashes	OPEN

6-3. Parts Replacement.

6-3-1. Replacing the Nameplate.

Pull the indicator body out slightly from the housing, open the lid on the top of the front panel, and replace the nameplate with a new one. (See Figure 6-6.)

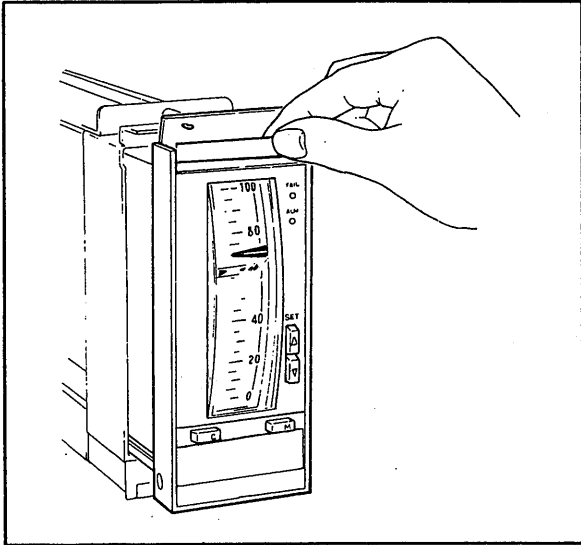

Figure 6-6. Replacing the Nameplate.

6-3-2. Replacing the Scale Plate.

- (1) Pull the indicator body out slightly from the housing.
- (2) Remove the scale plate retainer and the scale plate using tweezers. (See Figure 6-7.)
- (3) Insert a new scale plate. Insure that the measurement pointer and setpoint index indicate 0% on the scale when the measurement input and setpoint are set to 0%.

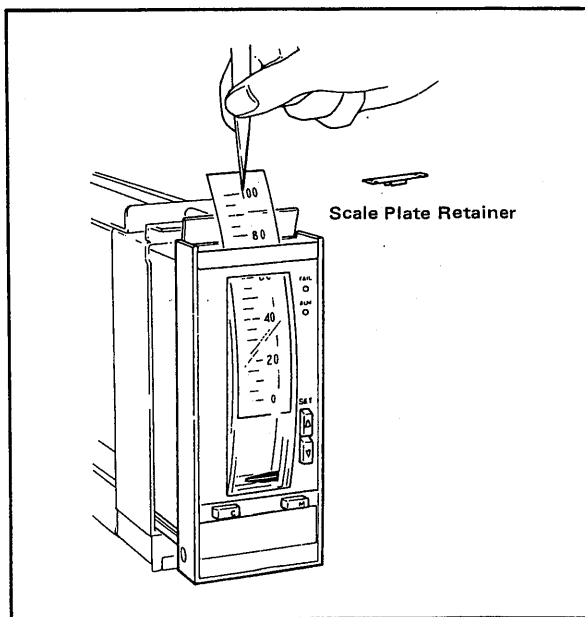

Figure 6-7. Replacing the Scale Plate.

6-3-3. Replacing the Fuse.

Remove the fuseholder cap located on the rear of the internal unit, and replace the fuse with a new one. (See Figure 6-8.)

Recommended fuse replacement interval: 3 years.

Fuse rating: 1 A.

Part number: S9510VK.

Tighten the fuseholder cap after fuse replacement.

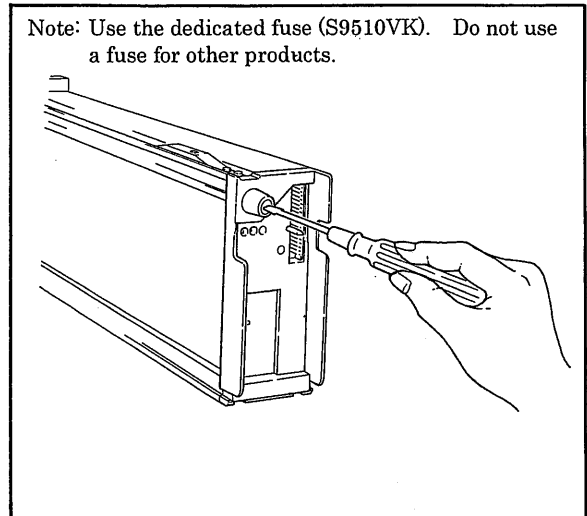

Figure 6-8. Replacing the Fuse.

6-3-4. Replacing the Data Protect Battery.

If the ALM lamp on the front panel of the instrument begins flashing, please replace the battery without delay.

Recommended replacement intervals:

About 5 years (charging, at ambient temperatures below 45°C)

About 1 year (shelf-life, at ambient temperatures below 45°C)

Note 1: To prevent loss of internal data, replace the data protect battery only when the power is being supplied to the unit.

- (1) Pull the internal assembly out from the housing, and remove the battery cover and the battery case (the case and the battery are a single unit). (See Figure 6-12.)
- (2) Insert a new battery together with its case, and replace the cover. (See Figure 6-13.)
- (3) Ascertain that the front-panel ALM lamp is not flashing.

Note 2: Always replace the battery with its case as one unit; never replace the battery without its case.

Note 3: Never measure the battery voltage with a multimeter or similar test instrument with a low input impedance.

Note 4: To reinsert the battery in the case after it has been removed for some reason, observe the battery polarity, by confirming that it matches the symbols on the case.

Precautions on Handling and Storage of Data Protect Battery

- (1) Ambient temperature: -10 to 60°C.
Ambient humidity: 5 to 95% RH. Store in a corrosive gas free environment.
- (2) Do not attempt to recharge the battery.
- (3) Do not put the battery into a fire.
- (4) Do not short together the positive and negative battery terminals.
- (5) Do not apply heat to or attempt to disassemble the battery.

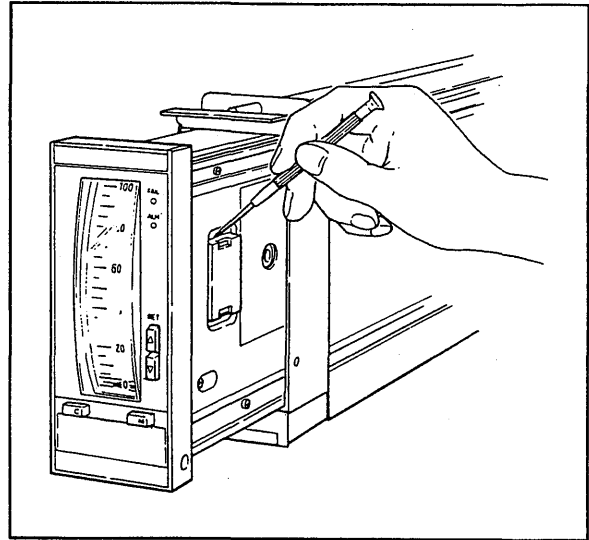

Figure 6-7. Removing the Data Protect Battery Cover.

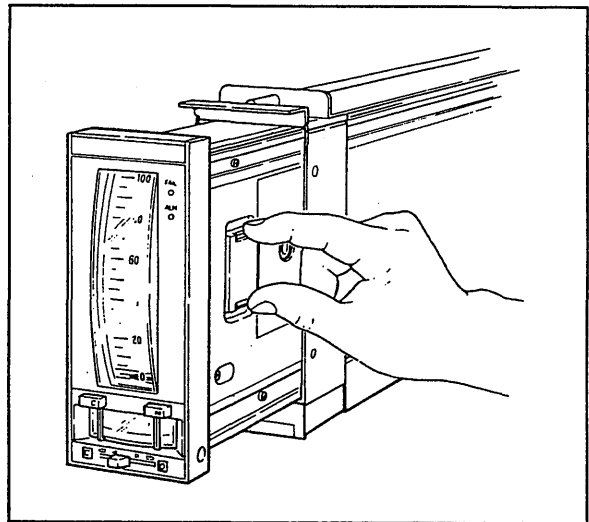
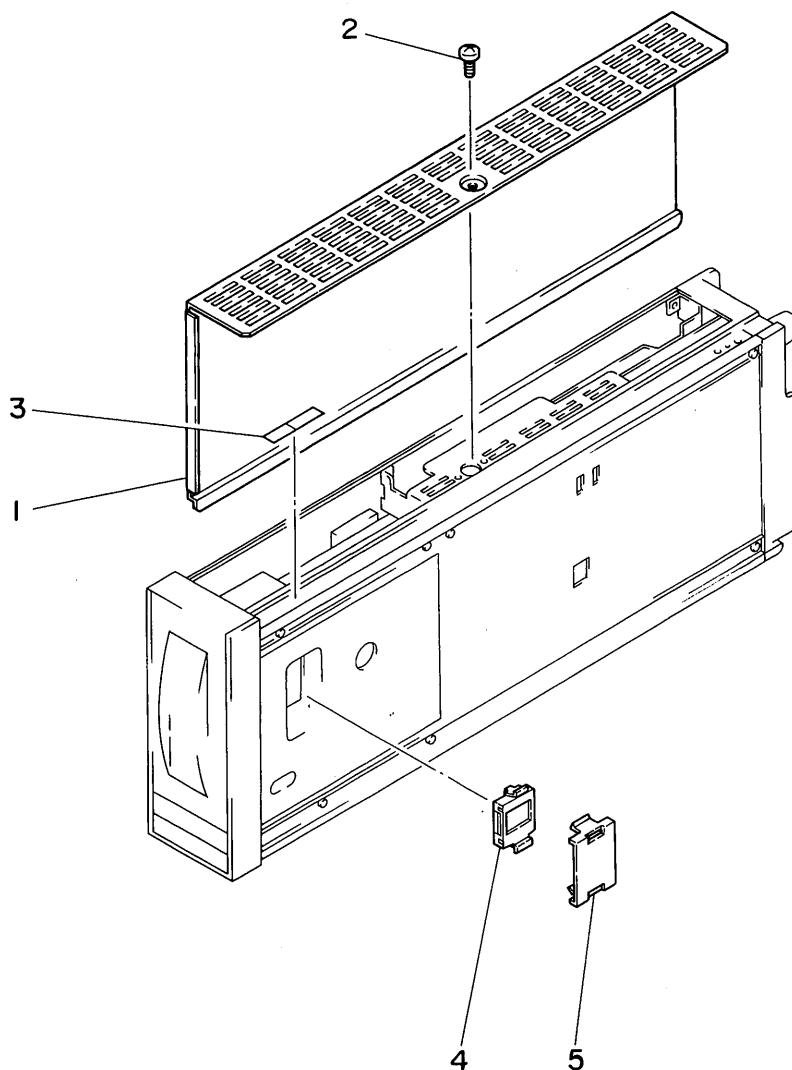

Figure 6-8. Replacing the Data Protect Battery.

Customer Maintenance Parts List

Model SMST (Style E)
Auto/Manual Station
(with C/M Switch)

YEW SERIES 80



Item	Part No.	Qty	Description
1	E9711TG	1	Cover
2	Y9405LB	1	B.H. Screw, M4 x 5
3	Y9422NP	1	Tag No. Label (blank)
4	E9711DH	1	Battery Assembly
5	E9711GQ	1	Cover

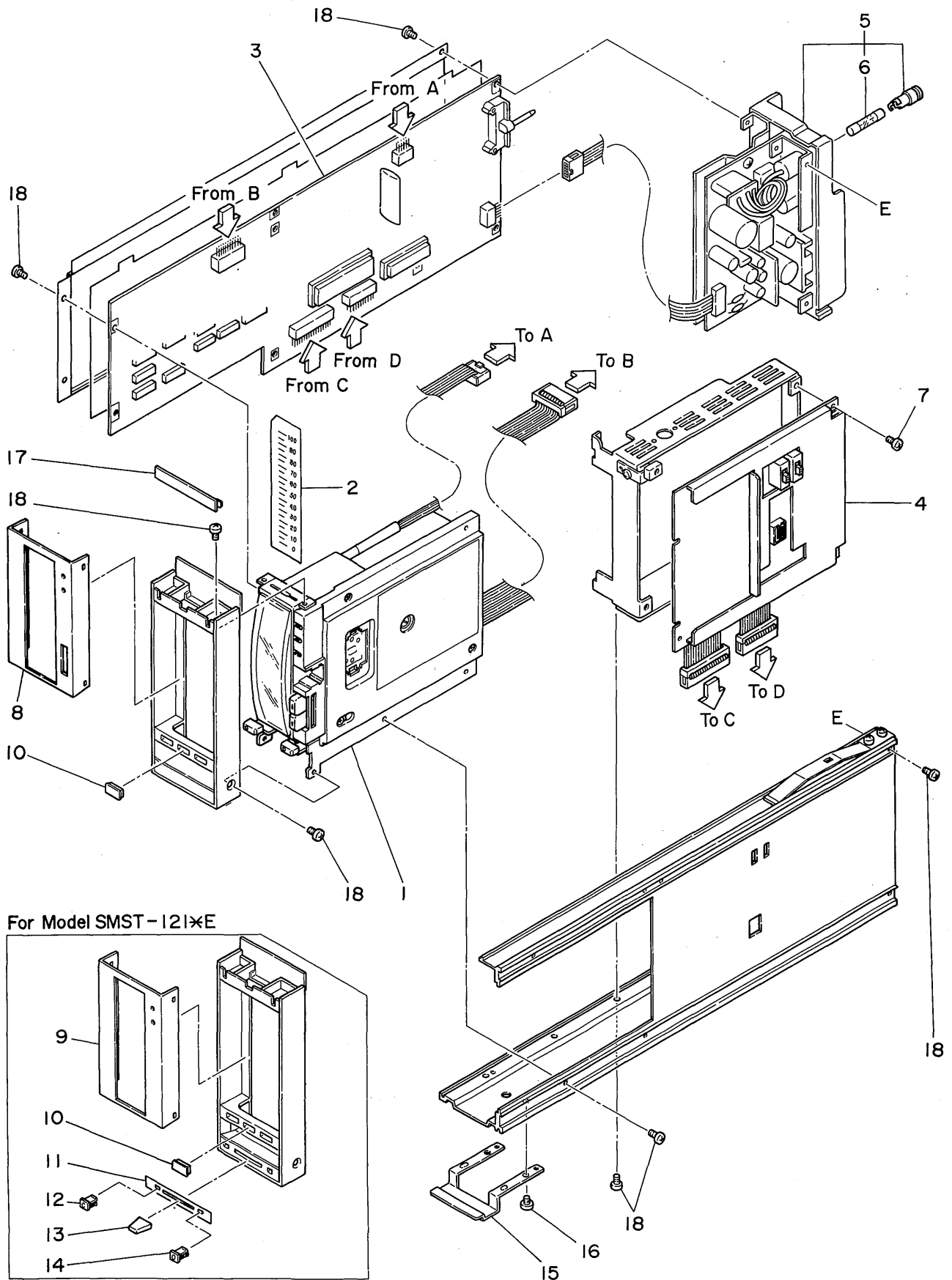

For Model SMST-121xE

Item	Part No.	Model		Description
		SMST-111	SMST-121	
1	E9714AV	1		Meter Assembly
	E9714AX	1		Meter Assembly
2	—	1	1	Scale (specify range when ordering)
—	—	1	1	Control Assembly
3	E9714LE	1		I/O Board Assembly
	E9714LF	1		I/O Board Assembly
4	E9714FE	1		CPU Board Assembly
	E9714FF	1		CPU Board Assembly
5	Below	1	1	Power Supply Unit
	E9716YB			For 100 V Version
	E9716YS			For 220 V Version
6	S9510VK	1	1	Fuse — "1A/250 V"
7	Y9306JB	9	9	Pan H. Screw, M3 x 6
8	E9711HA	1		Bracket
9	E9711HG	1		Bracket
10	E9711KH	1	1	Plug
11	E9711KE	1		Plate
12	E9711KC	1		Tip — "C"
13	E9711KA	1		Knob
14	E9711KD	1		Tip — "O"
15	E9711TD	1	1	Stopper
16	E9711TE	2	2	Screw
17	E9711FG	1	1	Plate (blank)
18	Y9306JB	14	14	Pan H. Screw, M3 x 6

E9714AV Meter Assembly (for Model SMST-111)
E9714AX Meter Assembly (for Model SMST-121)

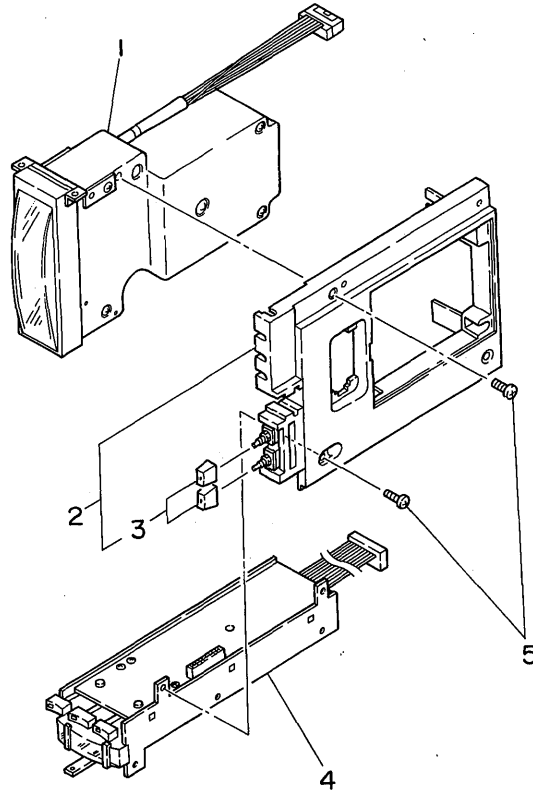

Item	Part No.	Qty		Description
		E9714AV	E9714AX	
1	E9714AB	1		Meter Assembly
	E9714AL		1	Meter Assembly
2	E9711DA	1		Frame Assembly
	E9711DB		1	Frame Assembly
3	E9711FH	2		Knob
4	E9711KK	1		A/M Unit (without Meter Assembly)
	E9711KN		1	A/M Unit (with Meter Assembly)
5	Y9306JB	5	5	Pan H. Screw, M3 x 6

Instruction Manual

/ HTB Power Supply Terminal Connections for Panel - mounted Instruments (Option)

1. GENERAL.

If you specify the terminal board to which the power source is directly connected (suffix code / HTB), the external wiring to the terminal board is necessary.

2. APPLICABLE INSTRUMENTS.

Model	Description
SRVD	Strip Chart Recorder
SIHM	Indicator (With Housing)
SIHF	Bar Graph Indicator (With Alarms)
SIHK	Indicator (With Alarms)
SLCD	Indicating Controller
SLPC	Programmable Indicating Controller
SLMC	Programmable Indicating Controller with Pulse → Width Output
SMLD	Manual Station
SMST	Auto / Manual Station
SMRT	Ratio Set Station
SCMS	Programmable Computing Station
SBSD	Batch Set Station
SLCC	Blending Controller
SLBC	Batch Controller
STLD	Totalizer

3. NAME OF COMPONENTS AND TERMINAL DESIGNATION OF POWER SUPPLY

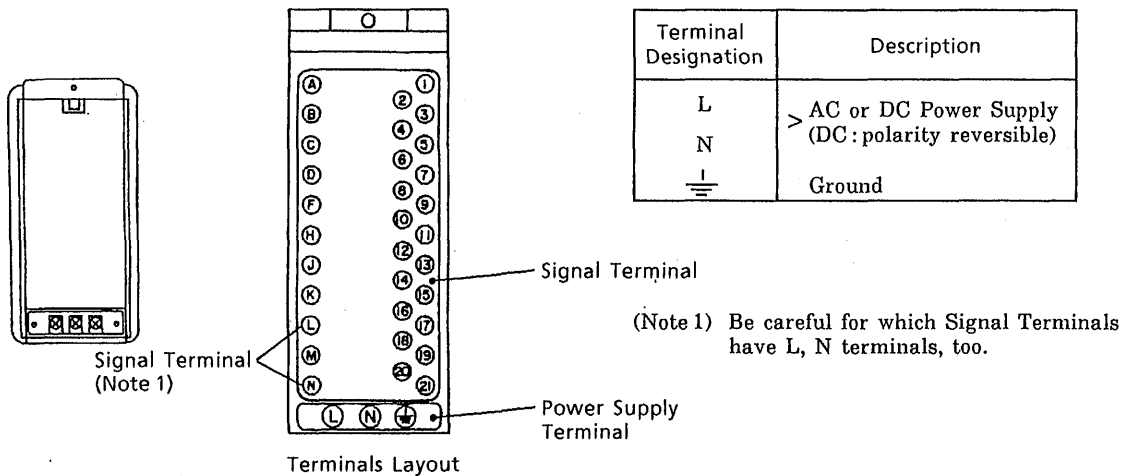

4. POWER SUPPLY AND GROUND WIRING.

- (1) All cable ends must be furnished with crimp-on type solderless lugs (for 4mm screw).
- (2) Examples of applicable cables.

Cross-sectional area of the cable conductor : 2.0mm².*

Note * : Power supply cables should be determined from the instrument power consumption - they must have conductors with cross-sectional area of at least 1.25mm².

Applicable cable : 600V vinyl insulated cable (IV), conforming to JIS C3307.

Vinyl sheathed cables for electric appliances (KIV), conforming to JIS C3316.

- (3) After completing the power supply and ground wiring, mount the power terminal cover.